

**Mains Protection Unit (R.O.C.O.F) VECFU5 (3- / 4-wire)
 voltage monitor with floating average value on a 10 minute range
 and frequency monitor**

*Release unit with partly features for self producing energy plant at low voltage mains acc. to
 DIN V VDE V 0126-1-1 : 2006-02 "Self switching place of disconnection"*

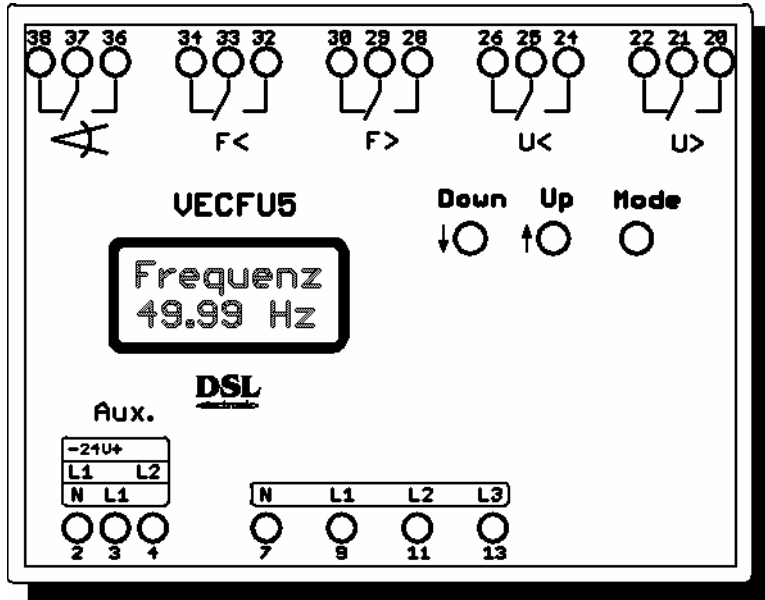

- Continuous monitoring and assessment of voltage, frequency and phase angle
- High-contrast LCD display with voltage and frequency display
- Settings can be called up directly
- Easy menu guidance
- Adjustments can be made during operation
- 5 output changeover contacts 250V 6A
- Watchdog monitoring

Application

The Mains Protection Unit VECFU5-ROCOF is used for power generators as diesel gensets, CHP's or AC inverters for monitoring and protection of parallel infeed into with the public network. The unit will be especially used for the monitoring of mains quality and cuts the supplier from public network by overdriving limiting values. The automatically disconnection is helpful to prevent damages of generators or equipment and will also be necessary to disconnect suppliers from mains. This can be necessary for service operations of net or in case of overloading. This can be done i.e. with increasing of frequency over 50,2 Hz which will be detected by VECFU5-ROCOF who disconnect the generator from net.

To guaranty for the safety of persons and equipment in smaller and middle sized paralleling power generators and to disconnect under special circumstances a commission of german VDE0126-1-1:2006-02 had fixed uniformly criteria of disconnection. The user of a "self switching place" receive with VECFU5 a switching unit which fulfills most parts of the VDE0126. The unit don't include an impedance measuring acc. 4.5 "Detecting of isle mode", with following note: for measuring of impedance there can exist difficult conditions of net esp. long cables to supply stations so a ROCOF detection could bring additional security. With adjusting of sensitivity of ROCOF from 1Hz/s to 10Hz/s it can be set to local situations.

The VECFU5-ROCOF includes a quick reacting frequency, ROCOF-detection and 3-phase voltage monitor which tests the mains changes for compliances with the limits. This also counts for the overvoltage protection acc. to VDE 0126 (moving average value in the voltage range of 110% – 115% across an interval of 10 minutes) which cause a disconnection from mains. All oversteppings are leading to immedeately switching (< 0,2 sec.) of relating output relay contacts of VECFU5.

With connecting of relay contacts acc. to connecting plan on page 4 a collecting signal will disconnect the power switch. With single connecting of output contacts each error can be monitored i.E. by SPC.

Note:

Immediately after mains failure or a frequency shift of the mains voltage, the parallel generator has to supply the entire network or the differential voltage caused by the frequency shift. The currents from the generator to the mains increase until they reach high values, but they do not lead to short-circuit triggering until after 100 - 500ms depending on the short-circuit protection. However, by then damage can already have been done, for example to the aggregate coupling, or the running aggregate can stall under maximum power and the continuing supply of gas or diesel to the engine can lead to deflagration. In addition to the necessary repairs,

other economic damage can be the result as the generator is now no longer available for the emergency power supply or because power can no longer be fed into the mains.

These disadvantages can be avoided by using the ROCOF protection unit, which disconnects the generator from the mains as soon as power failure or a frequency shift occurs.

Besides fast changes of frequency the VECFU5-ROCOF unit detect also "short disconnections" (KU) of mains and disconnects the power switch within 100-200ms. It may also be a advised disconnection of energy supply company for a time of 200-300ms to solve 80-90% of mains disturbances among others. After a waiting time 30 sec. the contacts of VECFU5 will be switch on the power switch again.

Function of Unit

The unit includes an under- and overfrequency monitor and one (3-phase) under- and overvoltage monitor with output change-over contacts. The output relays of the underfrequency and undervoltage monitor are on in normal operation and switch off after < 0,2 sec. when underfrequency or undervoltage occurs. The output relays of the overfrequency and overvoltage switch on after < 0,2 sec. when the preset limits are exceeded. Additional the VECFU5-ROCOF detects a frequency change on the power line and switches the output relay off (which is normally on in disturbance-free operation) when the value set (1-10Hz/s) is exceeded.

The limits for frequency jump, under- and overfrequency, under- and overvoltage can be adjusted by the customer as desired and saved permanently. The relays which are switched by mains disturbance are going back to normal position after **30 sec.** (to be changed).

With pushing "Mode" (for 1 sec.) first a event information appears on LCD-display. E: stands for the type of mains failure and T: for the count of minutes up to now. Always the last failure are showed. See also page 4.

Output Contacts

In off-running of VECFU5-ROCOF the output changeover contacts are in same idle state as printed on front label. After starting operation of set and correct values of voltage and frequency the U< relay will be switched on (contacts 24-25 be closed), the F< relay will be switched on (contacts 32-33 be closed) and the phase jumping relay will be switched on after delay time (contacts 36-37 be closed). With a serial circuit of all closing contacts (by rated voltage and frequency) a measuring circuit will be achieved to open a power switch by one failure on mains. See circuit diagram on page 4.

Technical Data

Type	Mains Protection Unit VECFU5-ROCOF
Design	Plastic housing on 35 mm DIN bar according to DIN EN 50022 / DIN 46277
Housing material	ABS with fire protection equipment UL 94 V-0
Dimensions, weight	100 x 75 x 109.5 mm (WxHxD), approx. 0.6 kg
Auxiliary power supply	231 / 400V 50-60Hz, +/-10% in each case, approx. 2.5W, other values available, option: 24VDC
Program safety	Watchdog function with automatic reset, failure of LCD display does not cause the functions to fail. Overall reset via simultaneous pressing of all 3 keys
Operating voltages	231V (L-N) / 400V (L-L), other values available
Voltage Measuring	Rectified value of each phase with noise limiter (low pass 50ms), Class 1.5
Trigger: voltage	Highest or lowest voltage value of one of the 3 phases (to N) in each case causes the output relay in question to trigger, releasing of "moving average value 110%-115% causes switching of overvoltage relay
Trigger time voltage	< 200ms (over- and undervoltage >1V over limit)
Operating frequency	45 – 70Hz, preset 50Hz, accuracy 0,05%
Trigger frequency	Limit values for Underfrequency <F and Overfrequency >F to be set
Trigger time frequency	< 200ms
Frequency jump	Adjustable Range 1 – 10 Hz/sec.
ROCOF Trigger algorithm	Continuous measuring of mains period starts with comparison of period 1 to period 0, by exceeding of settings the calculation goes to next period up to 5 periods (appr. 100ms), by not exceeding in each period the calculation will be start again. This means, that a ROCOF is detected after appr. 100ms without delay of output relay (2..5ms).
On-switching acc. VDE0126	On-switching of relay outputs after general reset or end of mains failure 1-300 sec. (default 30 sec.)
Switchover to standby	< 10V (L-N)
LED display refresh	Approx. 1 second
Contact rating	6A, 250VAC, contact mat. AgNi,Au-plated, alternations 10*10 ⁶ , min. switch. load 1mA 1V, max. 1,500VA
Voltage insulation strength	4000V (coil-contact), 1000V (open contact)
Terminals	Strand 2.5 mm ² , rigid 4mm ² , torque 0.5Nm, screw size M3
Protection class	Housing IP40 (EN60529), terminals IP20
Environmental temperature	-10 °C bis +45°C, 95% humidity
Mains isolation acc. to	EN 60 742 (safety transformers)
General regulations	EN 50 178 (electrical resources in power installations)
Radio interference voltage	DIN EN 55011, Edition: 2003-08, Class B
Radio noise field intensity	DIN EN 55011, Edition: 2003-08, Class B
Noise immun. ESD (housing)	DIN EN 61000-4-2, Edition: 2001-12, Electrical dischargings, Performance criteria B
Noise imm. HF-field (hous.)	DIN EN 61000-4-3, VDE0847-4-3:2006 EMV, High frequency irradiation, Performance criteria B
Noise imm. BURST(AC pow.)	DIN EN 61000-4-4, Edition: 2005-07 EMV, Transient noise signals, Performance criteria B
Noise imm. BURST (cable)	DIN EN 61000-4-4, Edition: 2005-07 EMV, Transient noise signals, Performance criteria B
Noise imm. HF-field(AC pow.)	DIN EN 61000-4-6, Edition: 2001-12 EMV, High frequency inflow, Performance criteria A
Noise imm. HF-field (cable)	DIN EN 61000-4-6, Edition: 2001-12 EMV, High frequency inflow, Performance criteria A
Voltage dip AC power	DIN EN 61000-4-11, Edition: 2005-02 EMV, Voltage dip, Perform. criteria B (10-20ms) and C (500ms)
Short interruption AC power	DIN EN 61000-4-11, Edition: 2005-02 EMV, Short interruption 0-5 sec., Perform. Criteria C
Self operating switching point	Acc. to DIN VDE 0126-1-1 together with corresponding switch-gear
Switching duration, maint.	100% ED, maintenance-free
Installation position	As required

Programming and Displaying of VECFU5-ROCOF

VECFU5-ROCOF works normally at any time in its main function as Voltage / Frequency Protection Unit, even though a service is reading or during changing the standard values on display menu. After saving of changed standard values the unit works with new settings. So you are able to change the settings during running system without problems.

Should only the **Standard Settings** be read, the „**Mode**“-Key must be push several time to get the different values on LCD-Display. In the following small table are the standard settings listed which can be changed from customer.

Remark: The settings can also be changed when only the auxiliary voltage (231V on terminals 2-3 or 400V on 2-4) be connected. Failure announcements on LCD-display are to be ignored. After changing the settings a check of the settings with the „Mode“-key will be recommended.

Display Functions with “Mode”

In normal running of VECFU5-ROCOF (mode key not activated) the display shows all 2 seconds one after another the voltage values **L1-N**, **L2-N**, **L3-N** and the **frequency**. With continuing pushing of **down** key the displaying point of value stops and the changes of values can be watched continuously.

With pushing of „**Mode**“-key the LCD-Display shows first the last event **E**: with information of back time **T**: in minutes. With next pushing of **mode** the display of the 10-minutes voltage average values acc. to VDE0126 of L1, L2 and L3 follows respectively. After this the service menu follows for changing of settings with edition of password (see later). After another pushings of **mode** the following settings are be showed on display.

U-System	L-N Min	L-N Max	Hz Min.	Hz Max.	ROCOF	Mittelw.	Type	Version
L - N	184,8V	265,6V	47,5Hz	50,2Hz	1 Hz/s	110%	VECFU5	software

When the unit shall display the voltage values of 400V System(L-L) instead on 231V (L-N) the standard values must be changed. This is done inside the menu-point “**U-System**”. Here the figure L – L must be set to the lower line and with “zurück” (back) and “sichern” (save) the display will be changed to L-L.. Every time a switching back to L-N is possible.

Remark: With switching of L-N to L-L several times failures on last digit are possible.

Programming of Settings

Preliminary Remark:

During programming inside the menu the choosing of the next menu follows the point on the lower line of LCD-display. That means, with Up or Down you set the choosen menupoint to the lower line and enter with „Mode“-key. Then maybe another branching are necessary. When the flashing values are achieved they have to be changed with Up or Down.

The keys have been holding pushed for appr. 1 second in any menu. This avoids changing of values by mistake.

During operating inside the menu the display changes back to normal display when no changing was made within 30 seconds.

Programming:

With „Mode“-key 5 x (at a time 1 Sec.) pushing until display **Service**: obtained. **Up**-key 2 x pushing, until value becomes 2 (=key-figure) and then enter with **Mode**-key. You are now reaching the main menu, with the menu points **Test** (Test functions for choosen relay-output), **Setup Lx** (Voltage settings), **Setup Fq** (Frequency settings), **ROCOF** (ROCOF settings), **U-System** (switch over to L-L), **Service** (Setting of new password, 100-250) and **Zeiten** (End of faillure delay time). Choosing of wanted menu point to lower line, enter with „Mode“ or branch into further menus until the choosen value is flashing.

Trimming and saving of settings:

The flashing value can be changed with Up or Down keys. After setting of the new value enter with „Mode“ key, now the menu changes to upper menu-point. Now you either you go back with “**Zurück**” (back) or branch into other points (You are allowed to change several values at a time)

At the end of settings you go back to „**Sichern**“ (save), or „**Abbruch**“ (break). With „Sichern“ standing on lower line the changed values will be saved after entering the „Mode“-key (hold on 1 second). After this moment the unit works with the changed operating values. It is recommend to check the values in the displaying menu with the „Mode“-key.

Displaying of Events

After 1 x pushing of menu-key the display shows the last events with their lasting time in minutes. The display shows a 2-figured code for the type of event.

Following Display means

E:	FL	Frequency low
T:	100	100 Minutes (Event 100 minutes before)

Event code:

0 : no Event	PA : Parameter changed	1L : L1-N Low (Undervoltage L1-N)
1H : L1-N High (Overvolt. L1-N)	2L : L2-N Low (Undervoltage L2-N)	2H : L2-N High (Overvoltage L2-N)
3L : L3-N Low (Undervolt. L3-N)	3H : L3-N High (Overvoltage L3-N)	FL : Frequency Low
FH : Frequency High	RO : ROCOF exceeding	AV : exceeding of 10 minutes average value

Also some events for the manufacturer purpose, could be helpful for repairing.

Password setting

For all changes of settings the openly password “2” can be used. The customer or the personal from energy supply companies can change the passwort to 100 – 250 within the **Service** – menu (see above).

Other Funktions

Should of any reason a failure arise (program crash) a **reset** is possible with pushing all 3 keys at a time. After reset the display shows short times “DSL-electronic” and the unit works immediately. A **full reset** is obtained with off and on switching of auxiliary voltage with remaining of all settings made before.

Wiring Diagram

EAVECFU5.BRD

Circuit example of VECFU5 for paralleling operation

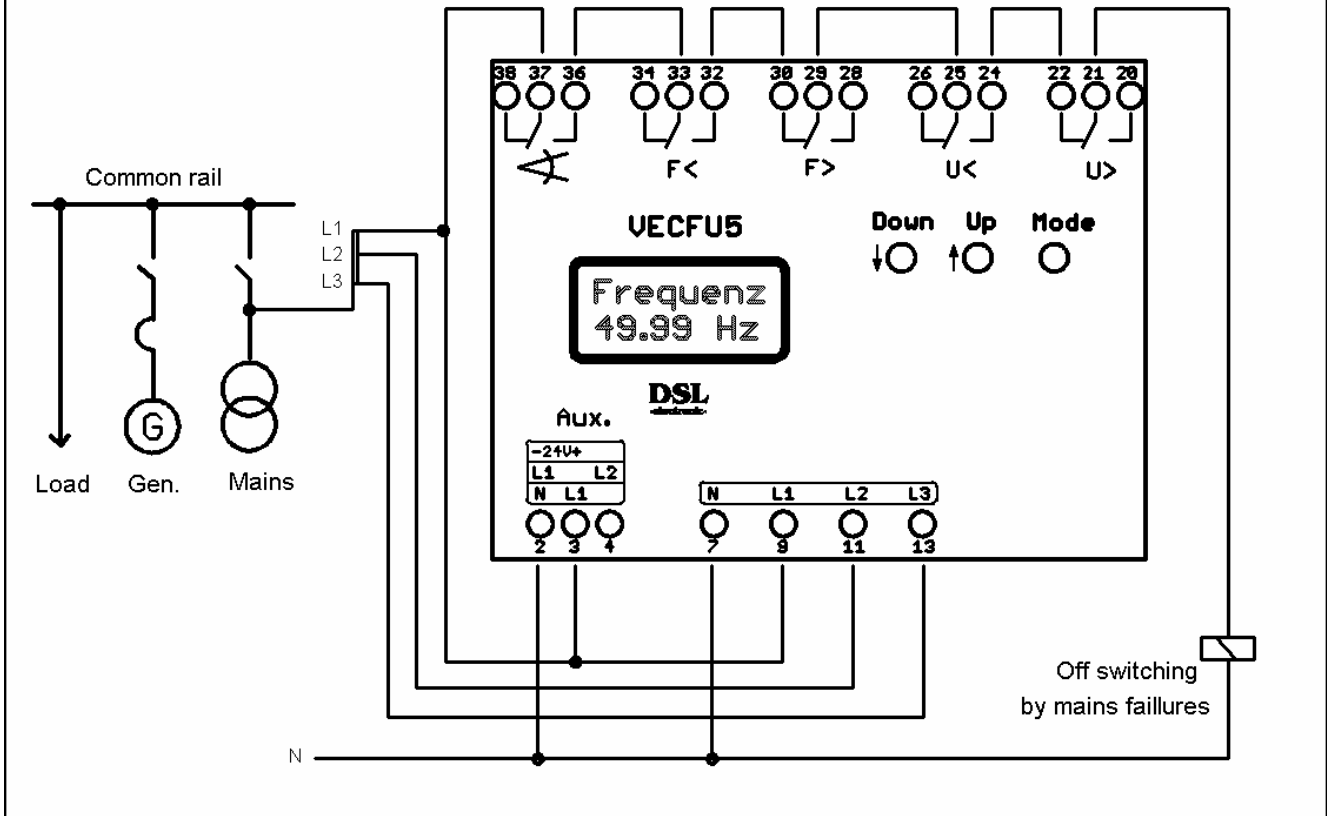

Menu guidance VECFU5-ROCOF

Continuous displaying of measurements
hold on of displaying value by
down-key keeping pushed

