

H0300 Event Logger

The SELCO H0300 Logger is a stand-alone logger system for the SELCO M1000C Alarm Annunciator, the M3000-30 Analog Alarm Annunciator, the SELCO M4780 Indicator and the SELCO H1500 Indicator Panel.

- Stand-alone logger unit
- Event log on display
- Event log on printer
- Repeating events from one slave unit to another
- Built-in siren relay
- Supports M1000C, M3000-30, M4780 and H1500
- RS485 interface for field-bus communication
- Standard MODBUS-RTU protocol
- Cable length up to 1000 metres on the bus
- PC configuration via RS232 interface

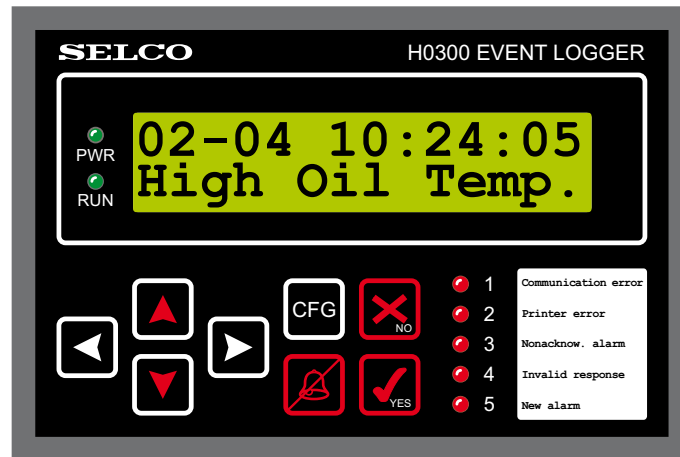

Application

The H0300 Event Logger can log alarms and events from SELCO alarm monitors and indicator panels, connected to a common 2-wire RS485 interface bus.

Up to 63 units can be connected to the bus, where the maximum cable length is approximately 1000 metres.

All events from the units are logged with related date and time. The latest 32 events are stored in the internal memory of the H0300.

A standard Centronics printer can be used for printout of all events.

The H0300 can also be configured to act as an event repeater. It can transfer LED indications from one unit to another through the common bus.

Multiple relations between source unit - LEDs and destination units - LEDs, where to repeat the indications, can be defined.

Function

The H0300 connects to the M1000, M3000, M4780 and the H1500 by the means of a two-wire RS485 serial communication bus.

The maximum length of the bus cable is 1000 metres; however various kinds of

RS485 repeaters can be used for extension.

The H0300 can survey a total of 63 units and it provides instant visible and audible alarm, should the communication fail to any one of the connected units.

The unit has a built-in siren relay for audible annunciation. Alarms and events can be acknowledged at the front panel.

A back-lit display is provided for on-site monitoring of the latest 32 events. Each event is logged with date and time. The display will automatically show both device number, channel number, LED state and a 32-character descriptive text.

The user can acknowledge each of the alarms located in the log by using the front panel keyboard.

Saturday, 07-12-2002		SELCO H0300 Event Logger				
Date	Time	Unit	Chan	LED st	Comment	
*** The printer was out of function from 07-12-02 16:21:02 to 07-12-02 16:23:23						
07-12-02	16:21:02	24	05	O f f	High oil temperature	
07-12-02	16:22:02	02	05	Steady	Emergency stop	
07-12-02	16:23:12	02	08	Steady	Overfrequency generator 3	
07-12-02	16:23:39	24	02	Quick fl	Overvoltage 24V	
07-12-02	16:25:44	24	05	Flash	High oil temperature	
07-12-02	16:26:39	24	05	Steady	High oil temperature	
07-12-02	16:32:11	24	02	Quick fl	Overvoltage 24V	
07-12-02	16:46:18	24	05	O f f	High oil temperature	
07-12-02	16:32:11	24	02	O f f	Overvoltage 24V	
Units present on the bus: 01 02 24						
07-12-02	16:23:25	02	03	Off	Emergency stop	
*** The printer was out of function from 11-12-02 12:31:47 to 11-12-02 12:45:04						
11-12-02	12:31:47	02	08	Steady	Overfrequency generator 3	
11-12-02	12:31:47	24	06	Quick fl	Overvoltage 24V	
11-12-02	12:33:43	01	05	Steady	Overvoltage generator 2	
11-12-02	12:33:50	01	02	Steady	Oil temperature diesel 2	
11-12-02	12:44:52	01	04	Steady		

Fig. 1. H0300 print out.

Four arrow keys are provided for navigation among the events in the memory log.

By default the display will show actual date and time plus the number of unacknowledged events present in the memory log.

The log has a battery backup system to preserve its contents during a possible power disruption.

A standard parallel printer with a Centronics interface can be connected directly to the H0300. The printer will provide a hard copy of the log showing every event captured by the H0300.

Each event is logged with date, time, unit number, channel number and a descriptive text. The log will also show any change made to the configuration of the H0300.

The correct function of the printer is continuously surveyed by the H0300. The printer must support 80 characters per line.

The H0300 can also perform an event

repeating function. This function provides the convenient feature of transmitting a LED indication from one unit to another (through the 2-wire bus connection).

The user can define any number of relations between the LEDs of the units connected to RS485 bus. Thereby it is not necessary to hardwire outputs to inputs, as the indication is transmitted over the common two-wire bus connection.

On the front panel of the H0300 are five LEDs. These LEDs provide visible indication of alarm status, communication and printer errors.

A retractable paper label is provided for local language descriptions. Two LEDs will show the operational status of the H0300.

The H0300 includes a real time clock and calendar. The date and time can be set directly on the unit. Summer and winter times are adjusted automatically (can be disabled).

Various logging functions can also be configured using the front facia LCD and keyboard.

Advanced configuration is done through the built-in RS232 connection using any personal computer with an ANSI terminal application (e.g. Windows HyperTerminal - see fig. 4).

Various commands are available, for instance text descriptions of all events can be copied from the computer's storage to the H0300 using a simple write-text command.

On the rear panel are four dipswitches with the following functions (see fig. 2.):

Dipswitch no.:

- 1 Master mode (OFF)
- 2 No summer / winter time change (ON)
- 3 Printer is not used (ON)
- 4 Configuration from keyboard is denied (ON)

Resampling dipswitch 1: H0300 can only operate in master mode.

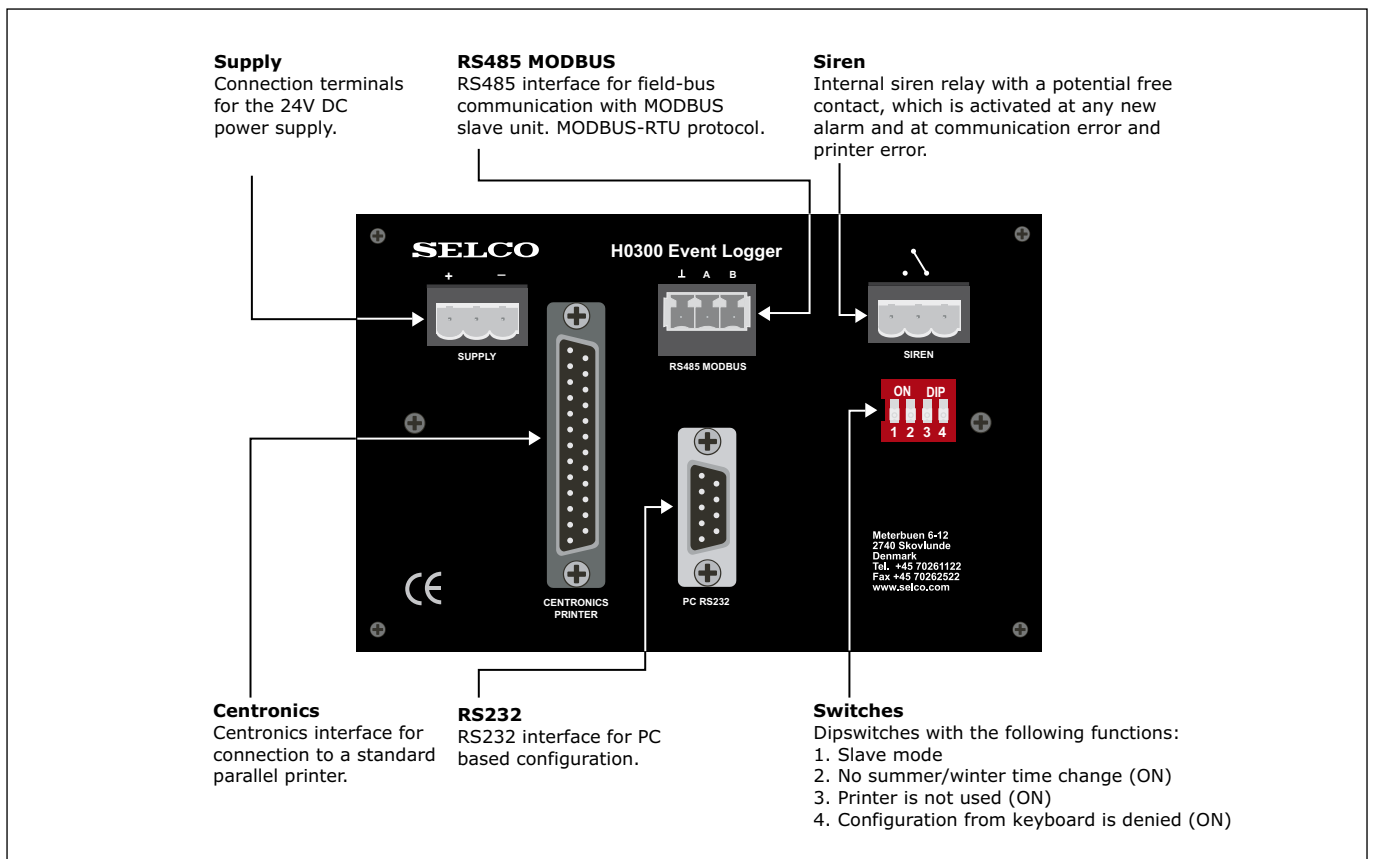

Fig. 2. Rear panel of the H0300.

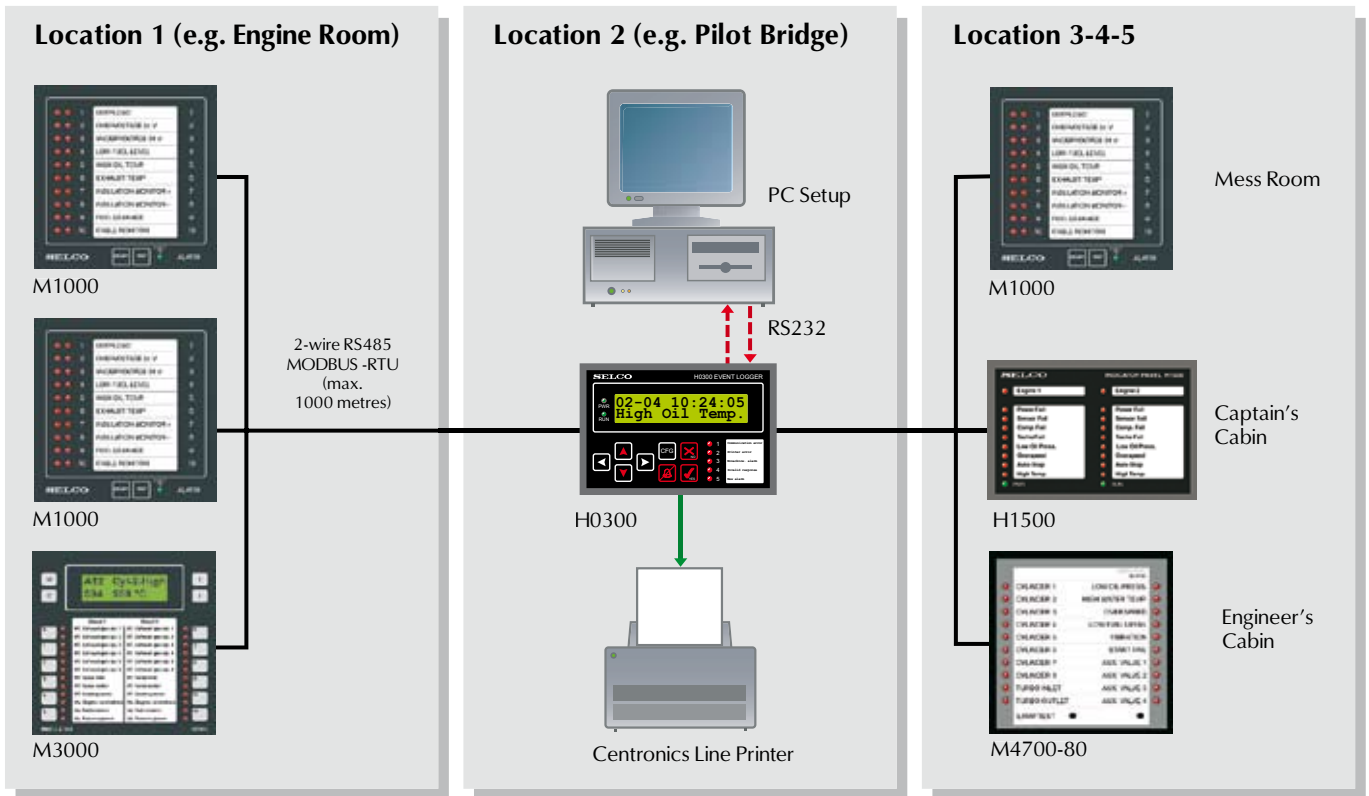

Fig. 3. Event Logging.

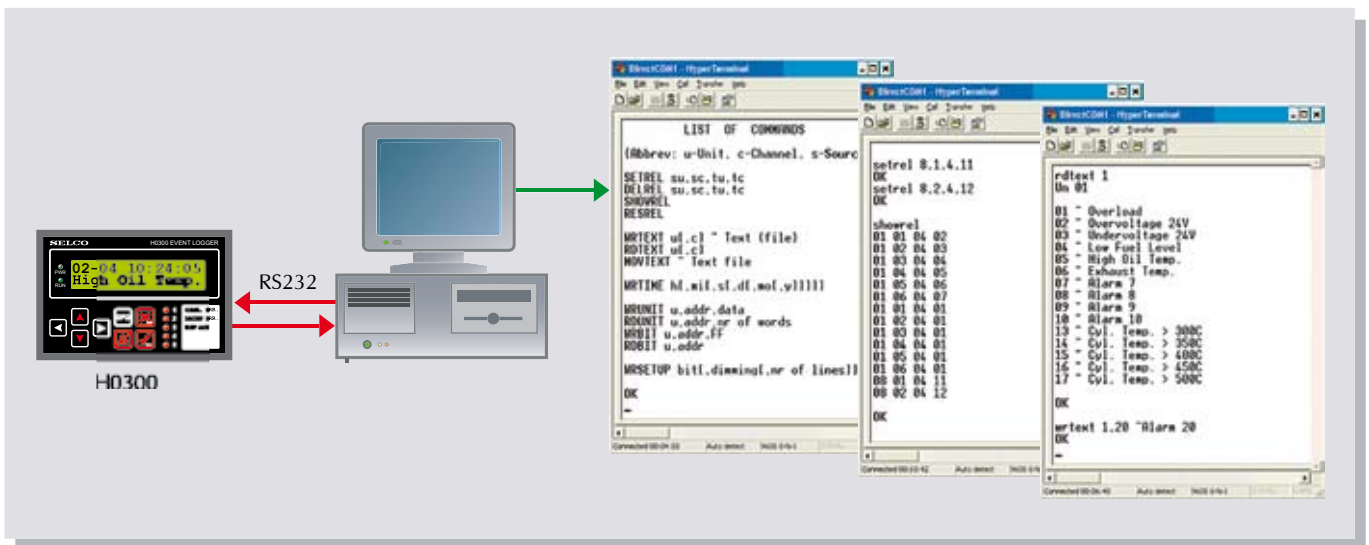

Fig. 4. Configuration via RS232 Interface using the Hyper Terminal.

Specifications

H0300 Event Logger

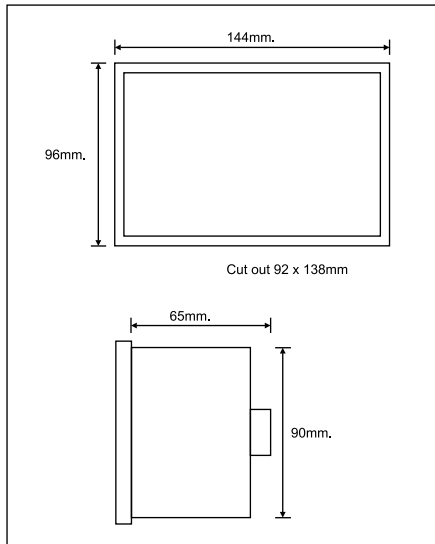

Fig. 5. Dimensions.

Voltage supply	24V DC -30%/+30%
Consumption	Max. 120mA (24V DC), 160mA (16V DC)
Bus system	2-wire RS485
Slave units	Support for 63 units, M1000C, M3000-30, M4780 & H1500. Note that M3000-30 occupies two addresses in the system
Relations	Max. 512
Programming	By keyboard / display or through RS232 (ANSI Terminal)
Display	Backlit 2 x 16 characters
Keyboard	8 keys
Siren relay	ND/NE 220V AC/2A 30 V DC/2A/30W
Alarm LEDs	5 LEDs Communication error (flashing) Printer error (flashing) Non-acknowledged alarm (steady) Invalid response (flashing) New alarm (steady)
RS485 parameters	9600 bits per second None parity 8 data bits 1 stop bit
Scanning period	T_s = number of units x 16 msec. T_{smax} = 63 x 16 msec. = 1 sec.
RS232 parameters	9600 bits per second None parity 8 data bits 1 stop bit
Printer	Centronics parallel printer (DB25), 80 characters per line
Operating temperature	-10 to +70°C
EMC	CE according to EN50081-1, EN50082-1, EN50081-2, EN50082-2
Burn-in	50 hours before final test
Weight	0.5kg
Dimensions	96 x 144 x 64 mm (H x W x D)
Panel cut out	92 x 138 mm
Protection degree at front	IP52

The specifications are subject to change without notice.

SELCO Worldwide



Main Office:
SELCO A/S
Betonvej 10
DK- 4000 Roskilde
Denmark
Phone: + 45 - 70 26 11 22
Fax: + 45 - 70 26 25 22
e-mail: selco.dk@selco.com
www.selco.com