

T4000 Auto Synchronizer

- Automatic synchronization with voltage based speed control
- Adjustable stability and phase angle.
- Visual indication of bus voltage, generator voltage and closing signal
- Output adaptable to most electronic speed controllers
- Automatic or remote reset of output
- Cost effective and highly reliable compact design
- 50 hours burn-in before final test
- Operating temperature range: -20°C to +70°C
- Certified by major marine classification societies
- Flame retardant enclosure
- Screw or DIN rail mounting

Application

The T4000 Auto Synchronizer provides automatic synchronization of an incoming generator to a busbar in a minimum of time.

The T4000 operates in connection with most electronic speed controllers. Via the speed controller the T4000 controls the speed and phase of the generator in order to match it to the busbar. The T4000 will lock the phase and frequency once accordance is obtained, thus enabling the generator to stay in synchronisation with the bus bar without closing the breaker.

Together with the T4400 Load Sharer, the T4000 provides the optimal solution for generator control, both in marine and land-based applications. The T4000 is type approved by major marine classification societies.

Function

The T4000 measures the voltage across two phases on either side of the circuit breaker in order to obtain data on frequency, phase and voltage difference for closing the circuit breaker at phase accordance.

The limits for the closing signal are adjustable on the dial PHASE ANGLE. The phase can be adjusted between $\pm 6^\circ$ and $\pm 9^\circ$, and voltage difference between $\pm 10\%$ and $\pm 15\%$. When the difference in voltage, phase and frequency are within limit for 0.5 seconds, a closing signal to the circuit breaker is generated, provided that CLOSE ENABLE is activated (terminals 12 and 13 interconnected).

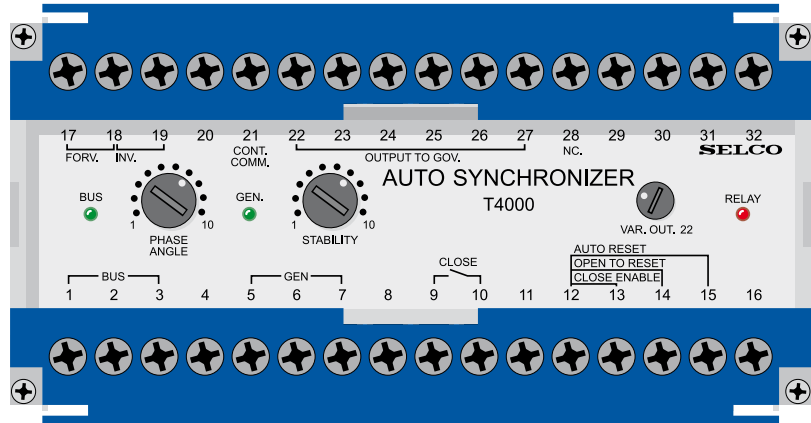

The relay LED indicates when within limits and a jumper between terminals 12 and 13 (CLOSE ENABLE) will enable the closing contact CLOSE (terminals 9 and 10). The closing signal is maintained for a minimum duration of 0.5 seconds.

When commissioning, it is recommended to disconnect the closing signal by opening the jumper between terminals 12 and 13. Check that the closing signal indicated on the relay LED is at phase accordance.

The DC control signal to the speed controller must be reset when the circuit breaker is closed. A jumper between terminals 12 and 15 (AUTO RESET) gives delayed automatic reset. Alternatively a normally closed auxiliary circuit breaker contact, connected to terminals 12 and 14 (OPEN TO RESET),

gives remote reset when the contact is opened. Reset is also obtained if the bus or generator voltage drops below approximately 50% of nominal voltage.

Impedance adaption of the output (OUTPUT TO GOV.) to individual electronic speed controllers can be done using terminals 23 to 26. Output on terminal 22 is variable (adjustable by a screwdriver at VARIABLE OUT 22).

Alternatively, other impedance values can be obtained by connecting an external resistor between terminals 21 and 27. The resistance is selected so that a speed deviation range of ± 3 Hz is possible.

The stability is adjusted on the dial STABILITY for the fastest phase accordance which does not cause overshoot.

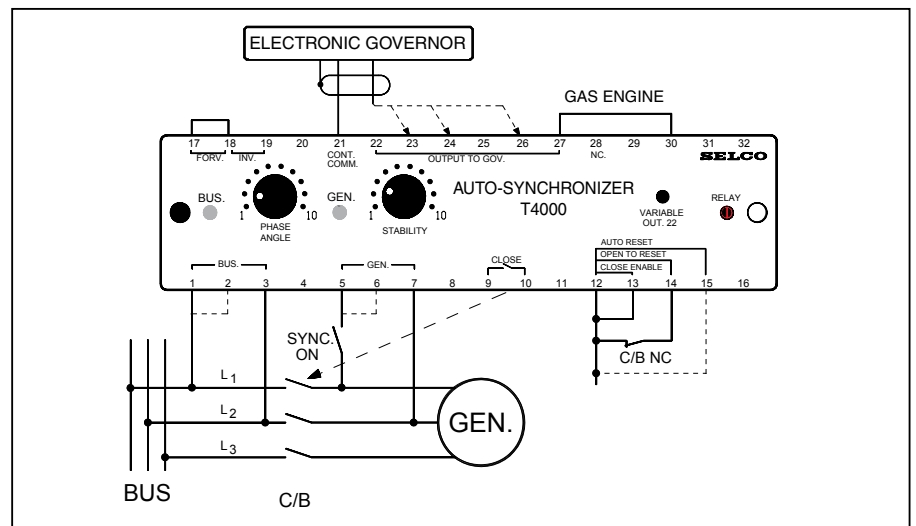

Fig. 1. Application Diagram.

Specifications

T4000 Auto Synchronizer

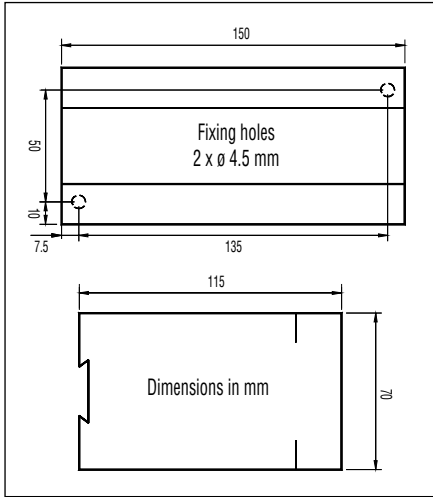

Fig. 2. Dimensions.

Connection between terminals 17 and 18 (FORW.) will control the output to a positive voltage for increasing frequency. A connection between terminals 18 and 19 (INV.) will give negative voltage for increasing frequency.

Type Approvals and Certificates

The T4000 has been approved by the following marine classification societies:



Bureau Veritas
Croatian Register of Shipping
Germanischer Lloyd
Romanian Register of Shipping
Russian Maritime Register of Shipping

Main office:
SELCO A/S
Betonvej 10
DK-4000 Roskilde
Denmark
Phone: + 45 7026 1122
Fax: + 45 7026 2522
e-mail: selco.dk@selco.com
www.selco.com

Max. voltage	660V
Voltage range	70 - 110%
Consumption	4VA at UN
Frequency range	45 - 65Hz
Frequency difference	0.15Hz
Closing angle	6 - 9°
Voltage difference	10 - 15%
Output voltage	Max. ±6V DC
Sync. time	Less than 5 sec. for engine response 0.2 sec.
Contact rating	AC: 400V, 8A, 2000VA DC: 35V, 8A, 150W
Operating temperature	-20 to +70°C
EMC	CE according to EN50081-1, EN50082-1, EN50081-2, EN50082-2
Approvals	Certified by major marine classification societies
Burn-in	50 hours before final test
Enclosure material	Polycarbonate, flame retardant
Weight	0.7kg
Dimensions	H x W x D) 70 x 150 x 115mm
Installation	35 DIN rail or two 4mm (3/16") screws

Output terminals

Terminal 21	Common
Terminal 22	1kΩ to 2MΩ, adjustable on the front. Turn clockwise for increasing resistance
Terminal 23	1.2MΩ
Terminal 24	820kΩ
Terminal 25	480kΩ
Terminal 26	100kΩ
Terminal 27	1kΩ, low impedance
Terminal 28	No internal connection

The specifications are subject to change without notice.

Type Selection Table

Type	Terminals	
	1-3 5-7	2-3 6-7
T4000.0010	450V	400V
T4000.0020	230V	
T4000.0030	480V	415V
T4000.0040	110V	100V
T4000.0050	127V	120V

Other supply voltages and specialities are available on request.