

# **D1000 Arc Detection Relay Manual**

## Contents

1	Introduction.....	4
2	Installation .....	5
3	Power Supply.....	6
3.1	AC Supply 100 V to 230 V.....	6
3.2	DC Supply 100 V to 250 V.....	6
3.3	DC Supply 12 V to 48 V.....	7
3.4	Battery Supply 24 V.....	7
4	Sensor Inputs .....	8
4.1	Photoelectric point sensors with cable monitoring .....	9
4.1.1	Connection of point sensors:.....	9
4.1.2	Installation of point sensors in the switchboard.....	10
4.2	A2000 fibre sensor with cable monitoring.....	10
4.2.1	Fibre .....	11
4.2.2	Receiver .....	11
4.2.3	Transmitter.....	12
4.2.4	Sensor adjustment according to fiber length.....	13
4.2.5	Sensor adjustment in small compartments.....	13
4.3	A0200 and A0300 point sensors without cable monitoring.....	14
5	Placement of sensors.....	15
5.1	Switchboard Protection .....	15
5.2	Transformer Protection .....	16
6	Current Sensor .....	17
7	Auxiliary Inputs .....	18
7.1	Inhibit.....	18
7.2	Trip.....	18
7.3	Reset.....	18
8	Outputs.....	19
8.1	Online.....	19
8.2	Service.....	19
8.3	Trip.....	19
8.4	Trip Coil output.....	20
9	D1000 LEDs .....	21
10	D1000 buttons.....	24
10.1	Mode .....	24
10.2	Trip.....	24

10.3	Reset.....	24
10.4	Mode + Reset .....	24
11	Configuration.....	25
11.1	Connecting to the PC .....	26
11.2	Description of the configuration tool.....	27
11.3	General description of buttons in the configuration tool .....	28
11.3.1	Revert.....	28
11.3.2	Reset.....	28
11.3.3	Save all.....	28
11.3.4	Reset page .....	28
11.3.5	Revert page .....	28
11.4	General Parameters: .....	29
11.5	Configuration of light sensors.....	30
11.5.1	Common delays and limits.....	30
11.5.2	Sensor 1.....	31
11.5.3	Front panel sensor .....	31
11.6	Configuration of current sensor .....	32
11.6.1	Setup .....	32
11.6.2	Limits and time delays .....	34
11.7	Configuration of digital inputs.....	36
11.7.1	Inhibit input.....	36
11.7.2	Trip input .....	37
11.7.3	Reset input .....	38
11.8	Configuration of trip output .....	39
11.9	Advanced settings .....	41
11.10	About.....	41
12	Event logging.....	42
13	Commissioning .....	43
13.1	Configuration of installed sensors .....	43
13.2	Testing the sensors .....	44
13.3	Testing the trip coil .....	44
13.4	Full operation Test (online) .....	45
13.5	Adjustment of Sensor Sensitivity.....	45
14	Specifications.....	46

# 1 Introduction

The D1000 Arc detection relay is a stand-alone and high speed arc protection unit for electrical power distribution systems. The D1000 supports both point and fibre sensor technologies for optical arc detection and the D1000 has inputs for up to six sensors. The sensors can be combined depending on the application and requirements.

In case of an arc fault, the D1000 detects and generates a tripping pulse in less than 1 millisecond. The tripping pulse is typically used to trip the circuit breaker(s) supplying the installation. The total arcing time is thus reduced to the mechanical opening time of the circuit breaker, which is approximately 50 to 75 milliseconds. The trip circuit is based on a solid state switch (IGBT), which providing fast reaction and sufficient drive capability for even the largest circuit breakers.

The D1000 can be powered from either a DC or AC source. If the unit is powered from AC, it can charge a backup battery, which can drive the trip circuit by 24 V DC.

## **Built-in over current protection**

The D1000 integrates 3-phase current measurements for detection of short circuit and over current with a reaction time of approximately 1 millisecond. This makes it possible to reduce unintended tripping from external light sources, e.g. lightning or welding flashes without the extra delay and expense of an external over current relay. The over current function can also be used to trip the breaker in case of short circuits or long-lasting overloads without arcing.

## **Efficient self-supervision**

The D1000 provides continuous surveillance of the complete system including the connected sensors. Any system faults, e.g. a sensor cable fault is indicated by a flashing online LED and is logged and reported.

## **Real-time event logging**

The built-in USB connection provides easy access to a real-time event log, which provides detailed diagnostic information on all events, including near misses and events related to daily operation (e.g. configuration changes, test, reset, and power cycling).

## 2 Installation

The D1000 is secured to the rear of the switch board using four 5 mm screws or alternatively DIN rail mounting. In case DIN rail mounting is intended, mounting brackets can be purchased separately from SELCO.

Please ensure that enough space is given around the module so that the plug-in terminals can be removed and re-inserted. The length of the cables should also allow for the easy removal and insertion of the plug-in terminals.

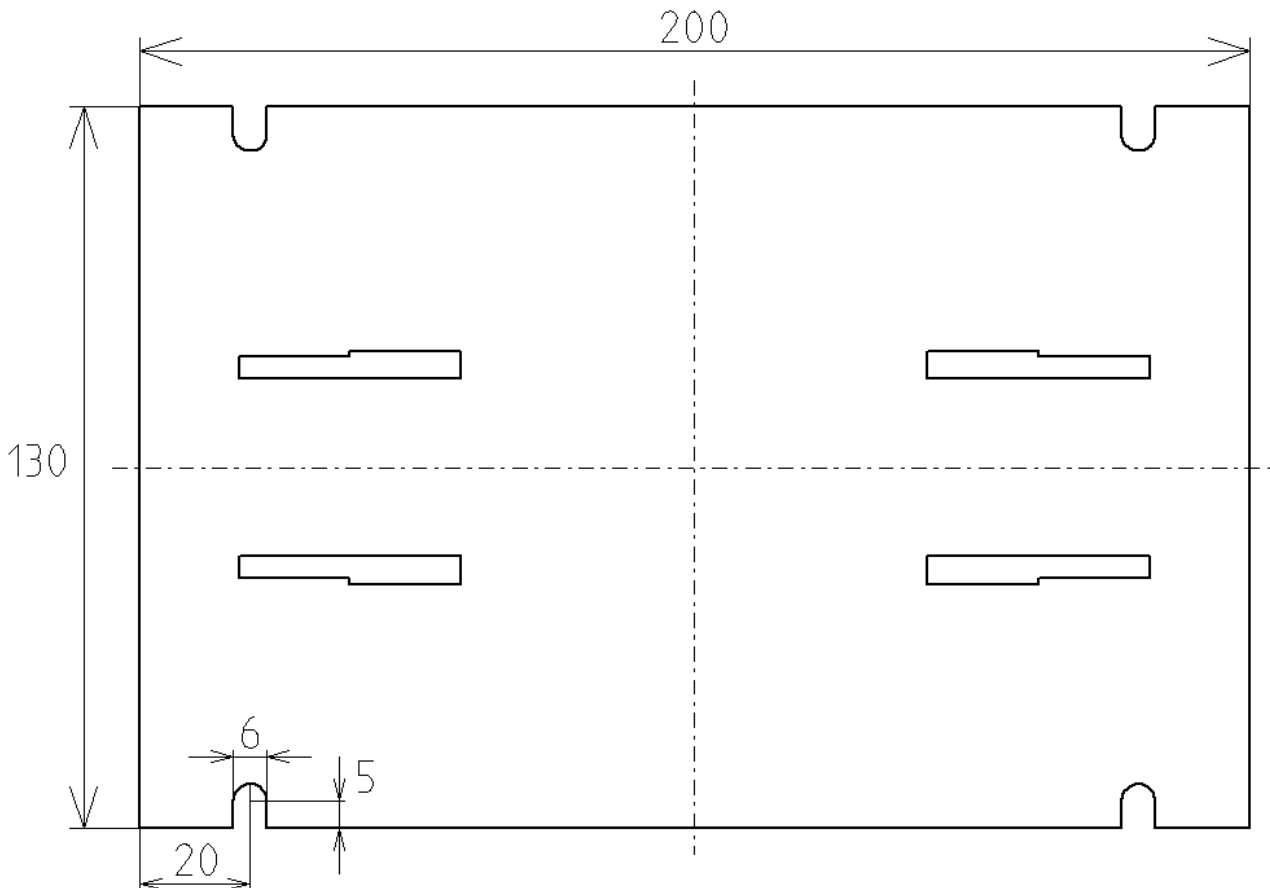

### 3 Power Supply

The D1000 Arc Detecting Relay can be supplied by AC or DC.

#### 3.1 AC Supply 100 V to 230 V

Terminals 31 and 32 are used for the AC supply. The supply voltage must be between 85 to 265 V (rated voltages from 100 V<sub>-15%</sub> to 230 V<sup>+15%</sup>).

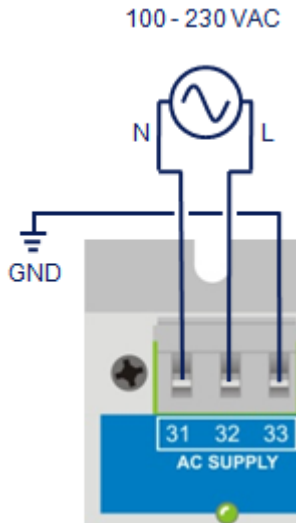

#### 3.2 DC Supply 100 V to 250 V

Alternatively terminals 31 and 32 can be used for the DC supply. The supply voltage must be between 85 to 300 V (rated voltages from 100 V<sub>-15%</sub> to 250 V<sup>+20%</sup>).

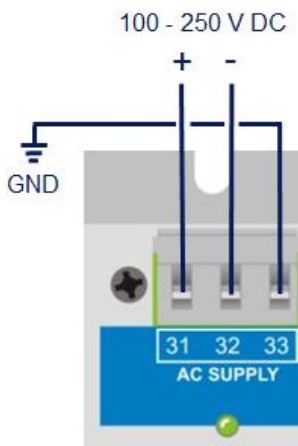

### 3.3 DC Supply 12 V to 48 V

Terminals 34 and 36 can be used for the DC supply. The supply voltage must be between 8 V to 63 V (rated voltages from 12 V<sub>-30%</sub> to 48 V<sup>+25%</sup>).

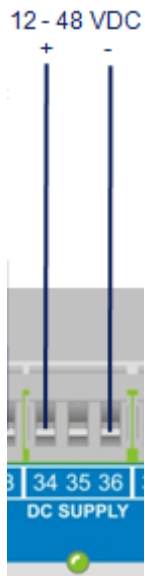

### 3.4 Battery Supply 24 V

Terminals 35 and 36 can be used for DC supply by battery. The battery (Gel Cell) voltage is 24 V DC.

**Note: The D1000 includes a battery charger that will maintain the battery fully charged as long as there is voltage on the power supply terminals 31 and 32 (regardless if this is AC or DC). The power supply on terminals 34 and 36 however will not charge the battery.**

In case the D1000 is charged by battery only and the battery voltage drops below 20 V, the D1000 will shut down in order to protect the battery. Arc monitoring is then suspended.

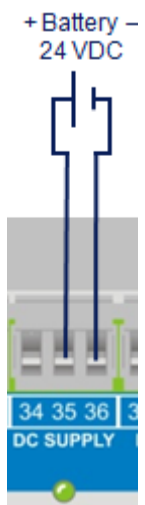

## 4 Sensor Inputs

6 sensor inputs for light sensitive sensors are available. Four different sensor types are supported:

- A1000 Photoelectric point sensors with cable monitoring
- A2000 fibre optic sensors with cable monitoring
- A0200 / A0300 Photoelectric sensors without cable monitoring

All inputs work in the same way and any type of above mentioned sensors can be connected.

Connection of the various types of sensors is explained on the example of SENSOR 1 input (terminals 1 – 4). All other sensor inputs can be connected in the same way.

### **A1000 photoelectric point sensor with cable monitoring**



### **A2000 fibre optic sensors with cable monitoring**



### **A0200 / A0300 photoelectric sensors without cable monitoring**



### 4.1 Photoelectric point sensors with cable monitoring

This sensor has a sensitive area of 180°. The sensor signal is a current signal (0 to 11.5 mA). The sensor is factory calibrated to 0.5 mA / klux.

The cable monitoring works via a built in LED that is fired once every second.

In case the sensor does not detect the light of the circuit check LED, the sensor fail alarm will be triggered.

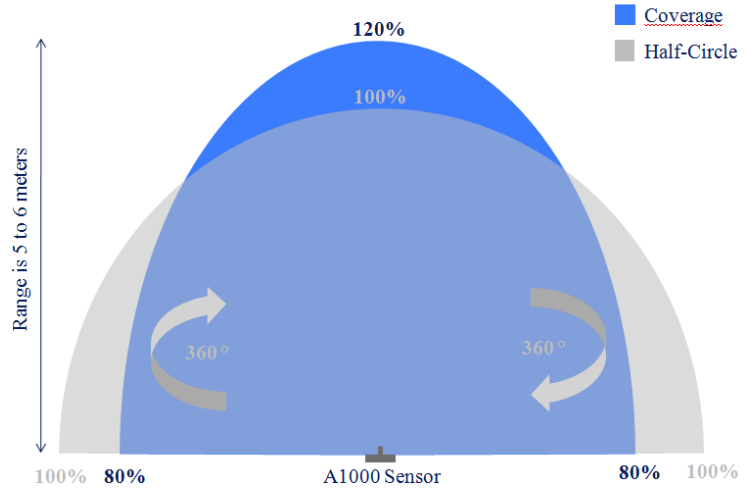

#### 4.1.1 Connection of point sensors:

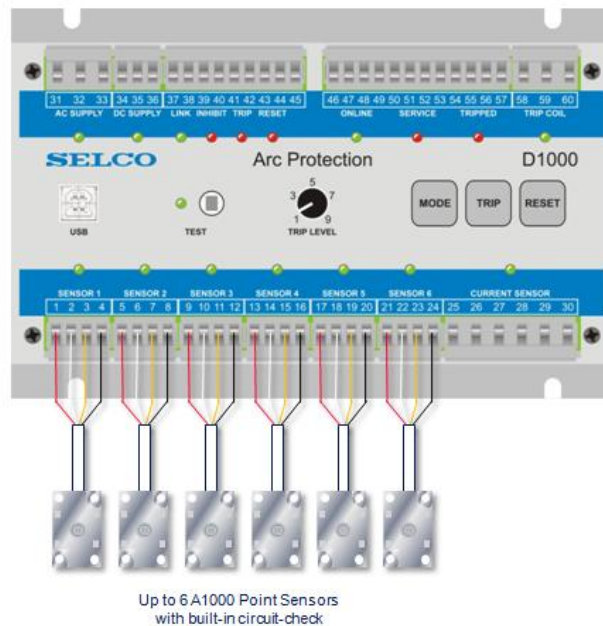
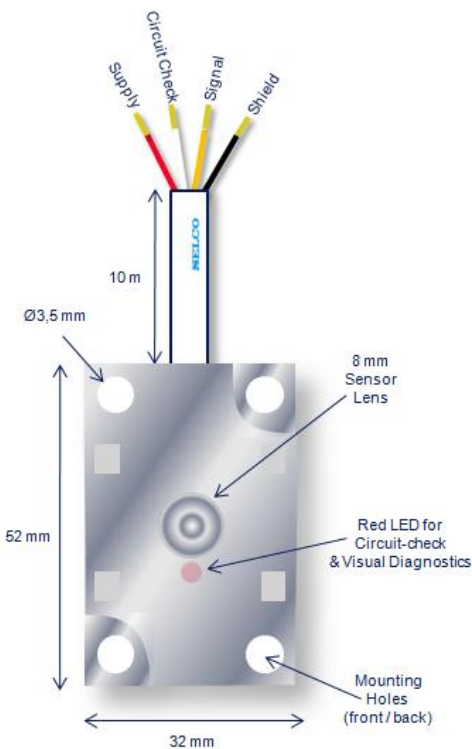

Terminal	Function	Colour
Terminal 1	Supply	Red
Terminal 2	Circuit Check	White
Terminal 3	Signal	Yellow
Terminal 4	Shield	Black / Copper

### 4.1.2 Installation of point sensors in the switchboard

The point sensors are delivered with an adhesive drill guide for easy installation in the switchboard.



1. Place the included adhesive drill guide where you want the sensor to be mounted.
2. Mark and drill 2 of the 4 holes directly through the drill guide (depending on how the sensor is to be installed).

3. Fasten the sensor using pop rivets or self-tapping screws.

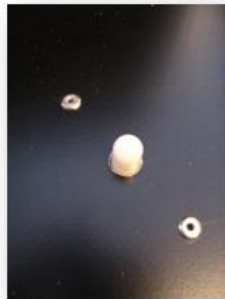

The sensor can be also be mounted "see-through" from the back of the cabinet.



## 4.2 A2000 fibre sensor with cable monitoring

The A2000 fibre sensor is installed in the same sensor terminals as the A1000 point sensor. However, there are more steps to connecting the A2000 due to the sensor being in three connected parts:

1. The fibre, with an end covered in black sleeve, and an uncovered end.
2. The receiver, white cabinet with a black finger screw and an adjustment screw in the cabinet
3. The transmitter, white cabinet with a white finger screw

Both the receiver and the transmitter are connected to the D1000 using standard flexible cable.

### 4.2.1 Fibre

The fibre is the light collecting element of the A2000. It must be mounted such that it has direct line-of-sight to all current carrying parts. This may be by following the bus bars along the back wall of the cabinets.

Connect the black sleeve-covered end to the receiver (with the black finger screw)

Connect the white uncovered end to the transmitter (with the white finger screw)

The fibre should not be sharply bent or pinched. The minimum bending radius is 5 cm.



The transmitter and receiver are mounted at the ends of the fibre, fastened to the walls using rivets or screws. The holes are prepared using the included drill guide, and the cables connected back to the D1000. The wires of the transmitter and receiver must be connected as follows (here shown for sensor port 1 on the D1000):

### 4.2.2 Receiver

Connect the red wire to pin 1

Connect the yellow wire to pin 3

Connect the white wire AND the shield to pin 4



### 4.2.3 Transmitter

- Connect the red wire to pin 1
- Connect the white wire to pin 2
- Connect the shield to pin 4



The end result is that a total of four wires end in terminal 4, and two in terminal 1. The best way of combining these wires is to use a large terminal tube crimped to all the ends. The sensor is shipped with the wires mounted in the terminal block for test purposes. As it must be disassembled for installation, the wires are not crimped together.

The cables can be shortened or extended up to 50 meters, but the transmitter and receiver must be independently shielded. Failure to do so can lead to false positives for the circuit check, e.g. that a faulty sensor is falsely detected as being present. This has no implications for the function – the sensor will still be able to detect arc faults.

After connecting the sensor, it must be adjusted according to the length of fiber in the individual cabinet compartments. The factory default is 60 cm/segment.

### Connection of the fibre sensor

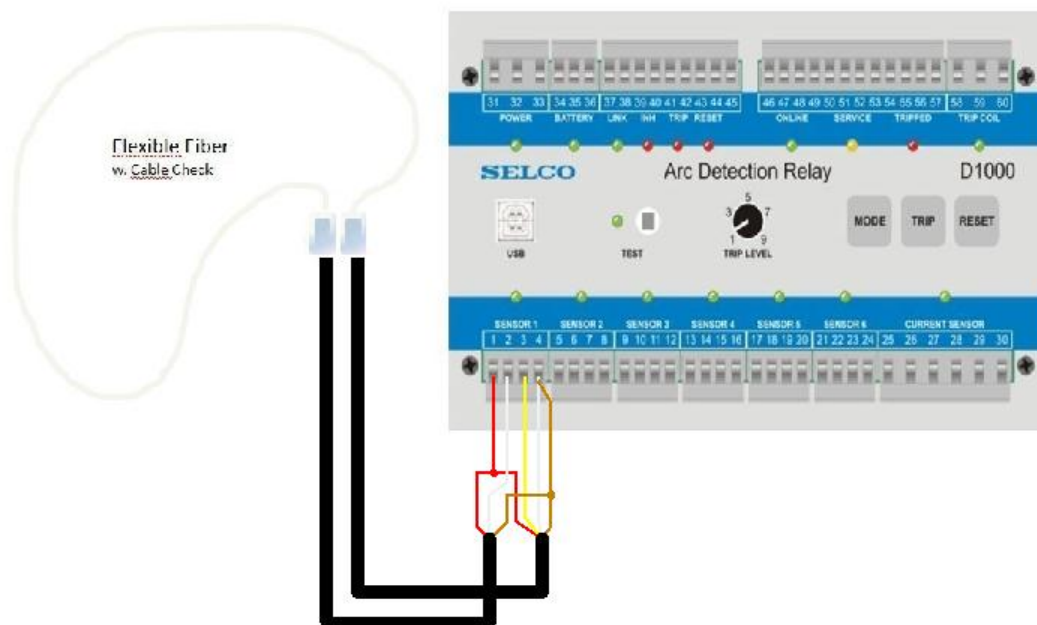

**Note: The fibre sensor comes connected to receiver, transmitter and D1000 plug in terminal. However, it may be necessary to disconnect it from the plug in terminal during installation.**

Terminal	Function	Colour
Terminal 1	Supply (transmitter/ receiver)	Red
Terminal 2	Circuit Check (transmitter)	White
Terminal 3	Signal (receiver)	Yellow
Terminal 4	Both shields, Circuit Check (receiver)	Black/ Copper

#### 4.2.4 Sensor adjustment according to fiber length

When delivered, the receiver is adjusted to give the same response at 60 cm of fiber installed per compartment as an A1000 point sensor. When using the fiber optical sensor in compartments where for example only 20 cm of the fiber is used, it is necessary to adjust the sensor sensibility. The sensor is unable to tell the difference between 10000 lux hitting 60 cm of fiber, or 30000 lux hitting 20 cm of fiber, as the same amount of light is transported through the fiber to the receiver. Thus, to achieve the wanted sensitivity, the receiver (with the black finger screw) must be adjusted away from the default setting in smaller or larger compartments.

This is done by using a powerful light source, e.g. an incandescent lamp of approximately 500W, and the following procedure:

1. Switch the D1000 to service mode by pressing the Mode button
2. Adjust the trip level setting to the lowest level (1) via the trip level dial on the D1000.
3. Slowly move the lamp towards the test sensor of the D1000
4. Note the distance from the lamp to the sensor, when the test LED lights up (approximately 50 cm).
5. Adjust the sensitivity level on the fiber receiver (black screw) to the lowest level. This is done by turning the small metal screw approximately 10 revolutions clockwise to its maximum level. Maximum level is when a little click sounds.
6. Place the lamp at the noted distance to the fiber sensor in the compartment closest to the transmitter (white finger screw), as this end of the fiber has lower sensitivity.
7. Turn the metal screw on the receiver counter-clockwise until the sensor indicator LED for the fiber lights up in red.
8. Adjust the trip level setting back to the desired position.

Now the sensitivity level of the fiber optical sensor is correctly adjusted.

#### 4.2.5 Sensor adjustment in small compartments

If the fiber optical sensor is used in multiple compartments of varying width, then the sensor must be adjusted in the compartment of the narrowest width. If the width of the narrowest compartment makes it difficult to follow the above procedure, e.g. because the lamp cannot be placed far enough

away in the compartment, the sensitivity adjustment procedure above can be adjusted in the following way:

1. Switch the D1000 to service mode by pressing the Mode button
2. In the compartment of the narrowest width – measure the distance from the fiber optical sensor to the lamp, when the lamp is placed at the point in the compartment where it is furthest away.
3. Set the trip level at maximum (9) on the D1000.
4. Place the lamp facing towards the test LED of the D1000, at the same distance as measured in point 2 (above).
5. Turn the trip level dial on the D1000 counter clockwise towards minimum (1) until the test LED lights up.
6. Continue from point 5 in the procedure above.

### 4.3 A0200 and A0300 point sensors without cable monitoring

A0200 and A0300 have originally been designed for the D0100 and D0900 Arc Detection Relays, but can be used with the D1000 as well. However cable monitoring is not available with these sensors.

They can be connected as follows:

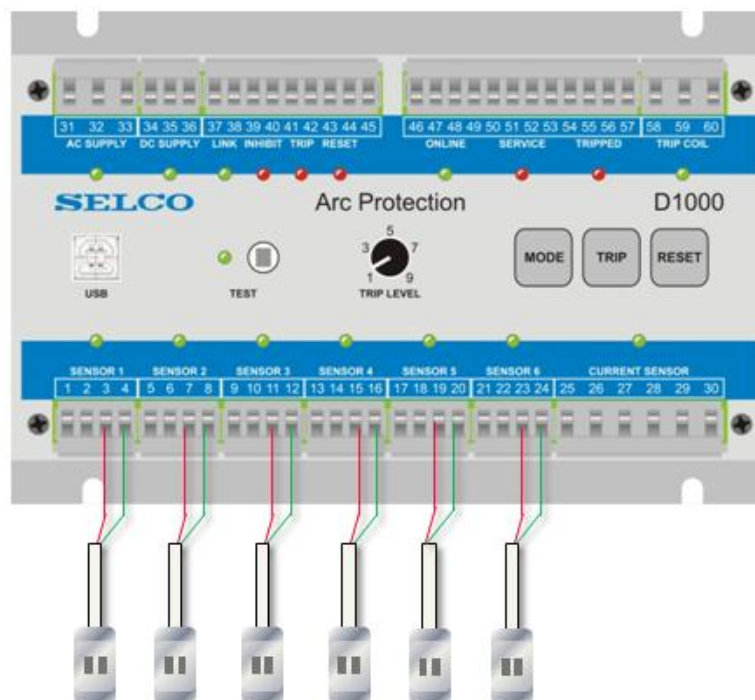

Terminal	Function	Colour
Terminal 1	Not Used	Not Used
Terminal 2	Not Used	Not Used
Terminal 3	Signal	Red
Terminal 4	Reference	Green

## 5 Placement of sensors

### 5.1 Switchboard Protection

The sensors used for arc detection are light sensitive sensors. This should be kept in mind when placing the sensors inside a switchboard. Free visibility from the point where an arc could appear to the place where the sensor is mounted is crucial.

Often it is sufficient to place one point sensor for monitoring of a complete switchboard compartment. If there are large components that cast shadows over wider areas (e.g. circuit breakers, more than one sensor would be required.

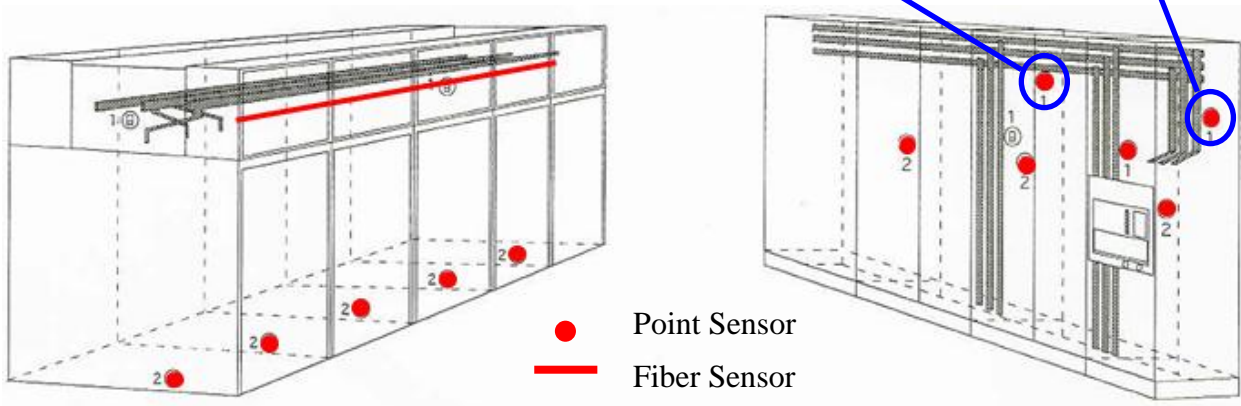
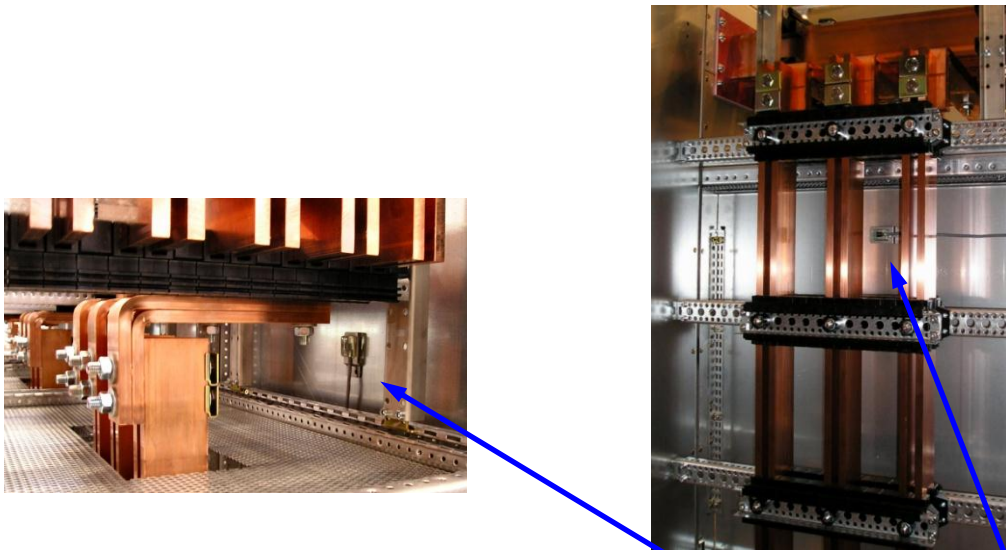

## 5.2 Transformer Protection

The Arc detection system is also used for protection of transformers. For the placement of the sensors the same considerations apply as for the switchboard protection.

Below pictures show an example of placement of the sensors in a transformer application.

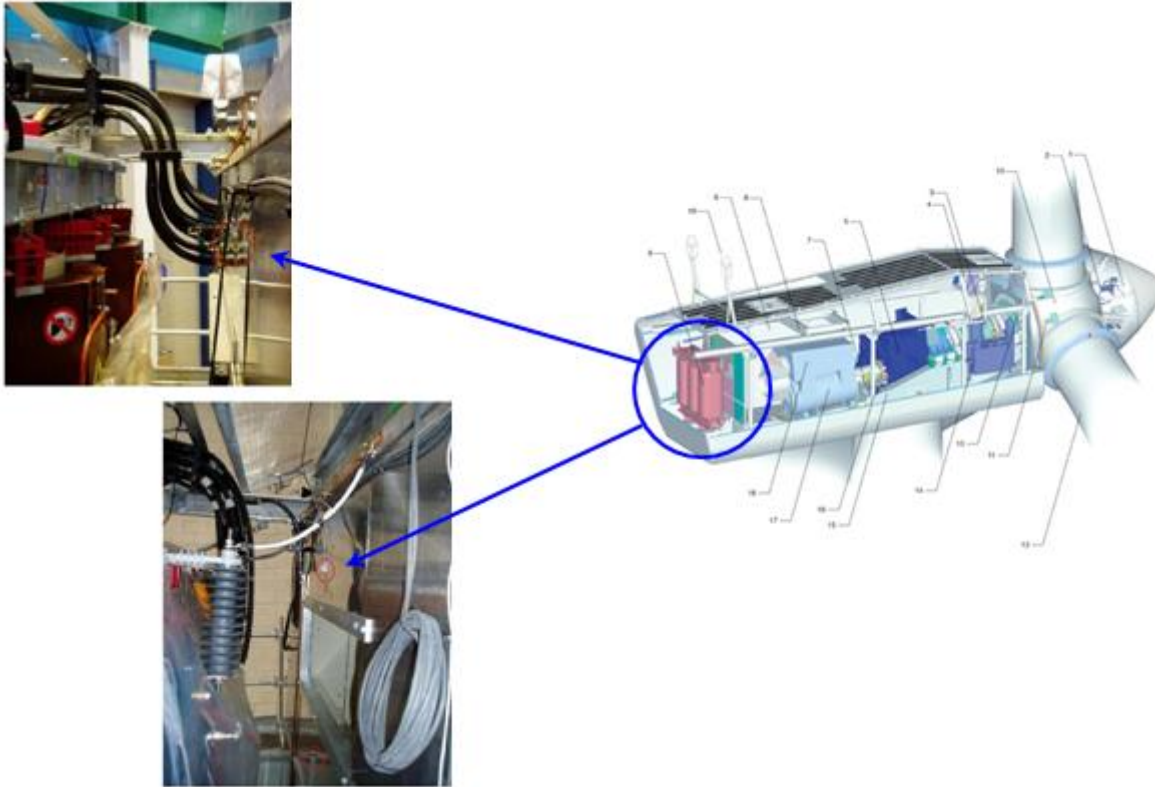

## 6 Current Sensor

The D1000 can be combined with an over current detection. When this function is used the D1000 will only trip when both conditions are fulfilled

- Light detection from the arc
- Over current detection

Purpose of this is to avoid false trips (e.g. when sunlight falls on the detector in case the switchboard door is opened).

Independent of this it is possible to configure separate over current and short circuit trips that will trip on current detection alone.

The current sensor input can be used with 5 A current transformers. The resolution is 100 mA. The accuracy is approximately  $\pm 1$  A. This low accuracy is due to the quick reaction time needed for arc detection.

The current sensor inputs are sampled at 2 kHz and will withstand 100 A for 1 s. The burden on the CT is less than 0.25 VA. The current sensor inputs are galvanic isolated from the rest of the unit up to 500 V AC. The D1000 is only looking at peak currents, and is insensitive to phasing and polarity. The current detection is not active by default, but must be set up using the USB configuration tool.

25-26	Current sensor phase 1
27-28	Current sensor phase 2
29-30	Current sensor phase 3

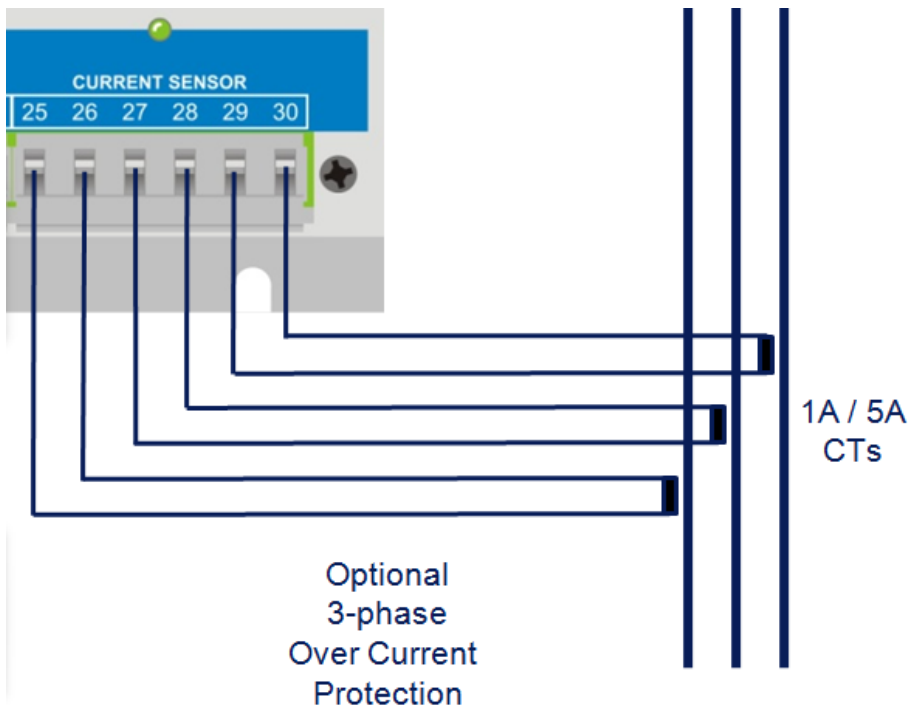

## 7 Auxiliary Inputs

All auxiliary inputs can be used with cable monitoring. This function must be enabled in the USB configuration. In case cable monitoring is intended a resistor of 82 k $\Omega$  must be connected in parallel with the contact. This resistor must be connected as close as possible to the contact.

The auxiliary inputs are all equipped with two terminals, which are internally connected.

Cable monitoring resistor (82 k $\Omega$ )

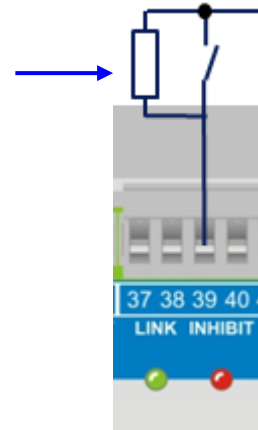

### 7.1 Inhibit

The inhibit input will suppress the trip signal.

When activated (connected to COM, terminal 45), the D1000 will only indicate that an arc fault is detected, but will not trip the breaker.

Inhibit will also block the remote trip command (terminals (41, 42)).

In case the D1000 detects an arc fault, the sensor LED will activate. When in INHIBIT mode, the INHIBIT LED will activate and the ONLINE relay and ONLINE LED will deactivate in order to show that monitoring is not active.

There are two terminals for activating INHIBIT mode, terminals 39 and 40.

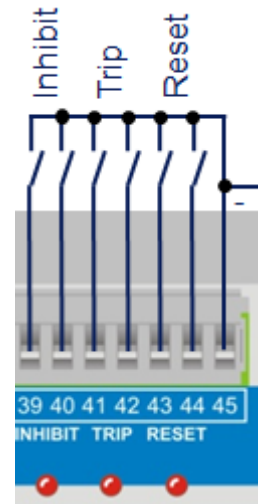

### 7.2 Trip

The trip input is used as a remote trip input. Once activated (connected to COM, terminal 45), the D1000 will trip the circuit breaker instantaneously.

There are two terminals for activating remote trip, terminals 41 and 42.

In SERVICE MODE this input is disabled.

### 7.3 Reset

The reset input is used as a remote reset after an arc fault. Reset is activated when connected to COM (terminal 45).

There are two terminals for remote reset, terminals 43 and 44.

Activating this input will reset an alarm or error; clear the trip output and the trip coil, clear the indicators, and place the unit back in normal mode – either Service or Online mode, dependent on what mode it was in before.

## 8 Outputs

### 8.1 Online

The online output is **normally energized**. It consists of two contact sets:

- A voltage free change over contact.
- A normally open contact with reference to COM (terminal 45).

The online output will remain activated during monitoring.  
The output will be deactivated in case the D1000:

- detects an arc
- detects a sensor fault
- loses power supply
- is switched to service Mode
- Inhibit is activated

The online output is shown in de-energized position in the drawing on the right.

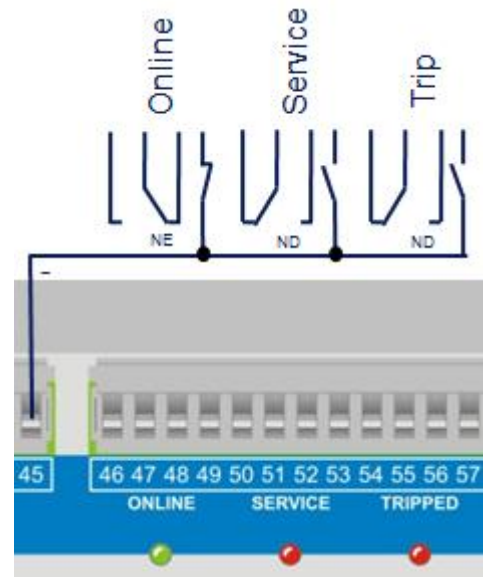

### 8.2 Service

The service output is **normally de-energized**. It consists of two contact sets:

- A voltage free change over contact.
- A normally open contact with reference to COM (terminal 45).

The Service output signals that the D1000 is being commissioned or set up.

The output will activate in case the D1000:

- is switched to service Mode
- is connected via a USB cable to a PC

### 8.3 Trip

The trip output is **normally de-energized**. It consists of two contact sets:

- A voltage free change over contact.
- A normally open contact with reference to COM (terminal 45).

The trip output is used for signalling a trip condition to a remote monitoring system. It is not used for the circuit breaker trip.

The trip output will activate in case the D1000 detects an arc and activates the C/B Trip Output (terminals 59 and 60).

The trip output will activate in case the D1000 detects an arc in service mode (without actually tripping the C/B).

## 8.4 Trip Coil output

The trip coil output is used for tripping the circuit breaker in case of an arc fault.

The trip coil output can be used for trip coils with supply voltages between:

- 24 V DC to 600 V DC
- 24 V AC to 440 V AC

The trip coil output is the main output of the D1000, and is activated in less than 1ms when a trip condition is detected.

The output is based on an IGBT transistor that is able to carry 10 A AC or DC for several seconds.

The trip coil output is galvanic isolated from the rest of the unit up to 1000 V AC.



**Note: The Trip coil output is an IGBT (Insulated-gate bipolar transistor) switch.**  
Please note that there is a voltage drop of 2-3 V over the IGBT trip coil output.

The trip coil output consists of a rectifier bridge and an IGBT. The IGBT is able to switch large currents and high voltages. In combination, this creates a very fast relay-like switch, which is able to trip even large circuit breakers without the extra delay of an external mechanical relay.



**Note: Thermal overload protection.**

The trip coil output functions as a momentary switch and is protected against thermal overload, and will gradually lower the time the trip coil is active if the D1000 is tripped continuously.

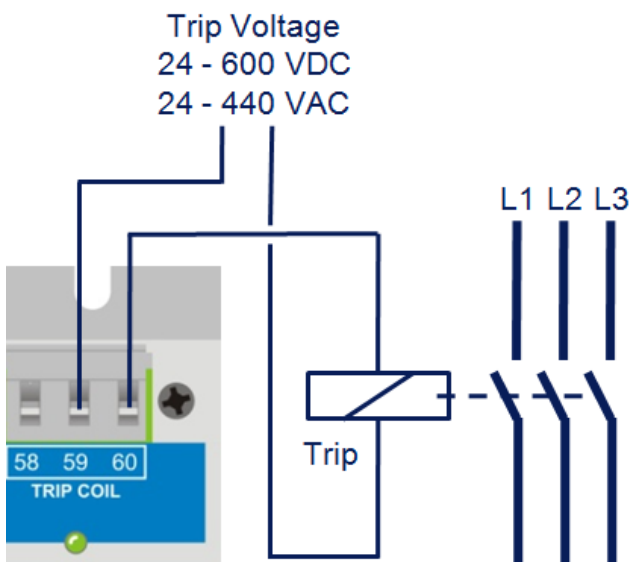

## 9 D1000 LEDs

### AC Supply

On	AC Supply is connected
Off	AC Supply is not connected

### DC Supply

On	D1000 is running from the DC input or from the AC supply
Flashing	D1000 is running from the Battery input. Be aware that the power supply will shut down at 20V to protect the battery from damage.
Short flashing	D1000 is charging a battery which is below the battery charge threshold
Off	D1000 is not powered

### Inhibit

On	Inhibit input is active or the current sensor is inhibiting trips.
Fast flashing	The D1000 has detected an arc (light), but the inhibit input or the current sensor is blocking a trip
Short flashing	Circuit check failed. Check the wiring of the input, or use the USB configuration tool to disable circuit check.
Off	Inhibit input is inactive

### Trip

On	Trip input is active
Fast flashing	Trip input is causing a trip
Slow flashing	Last trip was caused by this input or by the button on the front panel. Press reset in online mode to clear the trip.
Short flashing	Circuit check failed. Check the wiring of the input, or use the USB configuration tool to disable circuit check.
Off	Trip input is inactive

### Reset

On	Reset input is active
Short flashing	Circuit check failed. Check the wiring of the input, or use the USB configuration tool to disable circuit check.
Off	Reset input is inactive

**Online**

On	D1000 is online, active and operational. The output will trip if a trip event is detected.
Slow flashing	D1000 is online, but has at some point detected an error. The front panel LEDs will provide error information. Press reset to clear the error.
Off	D1000 is off or in service mode

**Service**

On	D1000 is in service mode. Please note that the unit will switch to and stay in service mode if a USB cable is attached. In service mode the trip output can be activated from the front panel trip button but not by arc fault, over current detection or trip input. By pressing reset, unit setup is activated.
Slow flashing	D1000 is in the process of auto set up or firmware update
Off	D1000 is without power supply or in online mode

**Tripped**

On	The trip coil output is or has been active. Press reset to clear the trip.
Off	No unacknowledged trips.

**Trip coil**

On, green	Trip coil output is ready and powered
Fast red flashing	Trip coil output is energized due to a trip event
Slow red flashing	Trip coil output has been activated (trip time has expired). Press reset to clear the trip.
Short red flashing	Trip coil output is blocking less than 5V → trip voltage missing, check the wiring and the power supply for the trip coil.

**Test**

On, green	Online mode: The sensor is configured for use as a trip sensor. Otherwise the LED indicates that the D1000 is booting. If this condition remains after booting, it indicates unit error.
Slow flashing	If the Service-diode is flashing, the D1000 is awaiting manual confirmation of the connected sensors (see 13.1)
Fast flashing	The internal supervisor or a USB host is reading or writing to the internal storage, or the light detected on the front sensor is close to trip level.

**Sensors**

On, green	Sensor input is active and has a connected sensor.
Fast green flashing	Sensor is currently detecting more than 50% of the arc flux needed to trip. This is a warning only. If this warning is active during normal condition, it may indicate that the system could generate unintended trips due to a too low detection limit.
Slow red flashing	Sensor caused a trip event. Press reset to clear the trip.
Short red flashing	Circuit check of the sensor failed. Check the wiring.
Off	Sensor input is inactive

**Current sensor**

On, green	Current sensor is activated and configured.
Fast green flashing	Current sensor is activated, and is detecting current > trip level.
On, red	Current is above the inhibit level. A high light level on a sensor will now cause the trip coil output to activate.
Slow red flashing	Sensor caused or did not inhibit a trip event. If the sensor LED is flashing alone, the trip was due to overload or a short circuit. Press reset in online mode to clear the trip.
Off	Current sensor is inactive.

## **10 D1000 buttons**

### **10.1 Mode**

Switches between online/service mode.

### **10.2 Trip**

In service mode, when pressed down for more than 1s, the trip coil output is activated.

### **10.3 Reset**

Acknowledge the trip (If in online mode and tripped).

In service mode, when pressed down for more than 1 s, the stored configuration is reset and the manual sensor confirmation sequence (see 13.1) is activated.

### **10.4 Mode + Reset**

Pressed down for more than 20 s initiates a factory default reset.

## 11 Configuration

The D1000 is configured with a PC using the USB interface.

The PC application for configuring the D1000 is built into the D1000 firmware and is pre-installed on the internal drives. When connected to a compatible PC using a USB cable, the internal drives of the D1000 are presented in the Windows file manager – similar to accessing the drives on a USB mass storage device.



**Note: HTA support**

*The configuration and log-viewer applications are implemented using HTA technology. This is a 'Microsoft-only' technology and is only supported by the MS Windows operating system with Internet Explorer 5.0 or later.*



**Note: USB Mass Storage**

*The USB Mass Storage technology is widely supported. The internal drives of D1000 containing the configuration and log files can be accessed by virtually any computer – Even if it is not running a Microsoft operation system.*

## 11.1 Connecting to the PC

When a USB cable is inserted, D1000 will go into service mode and arc detection is suspended. D1000 remains in this mode until the USB cable is detached.

When connected to a PC the D1000 implements a “USB key”-like feature (USB Mass storage) and two drives will appear in your file manager.

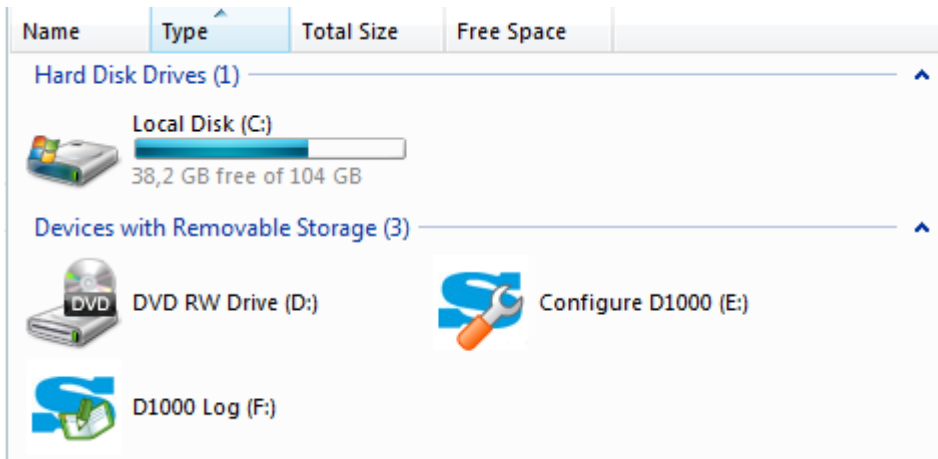

These drives behave like standard USB mass storage devices and the contents can be dragged and dropped to the drives.

The drives “D1000 Log” (the log drive) and “D1000 Configuration” (the configuration drive) are internal memory of D1000.



**Note: Circular log**

*When the log drive becomes full, the log-file will automatically remove the oldest log-entries in order to make room for new events. The log will always contain the most recent events.*



**Note:**

*The changes made through the configuration tool must be saved to the configuration drive – The configuration will be activated when the USB cable is disconnected.*

## 11.2 Description of the configuration tool

The configuration tool is saved on the configuration drive of the D1000. The configuration tool will open in the web browser. It is not necessary to install any programming software on the PC.

Double-click on the **config.hta** file in the root of the configuration drive and the configuration tool will open in your web browser (the configuration itself is saved in the **config.cfg** file).

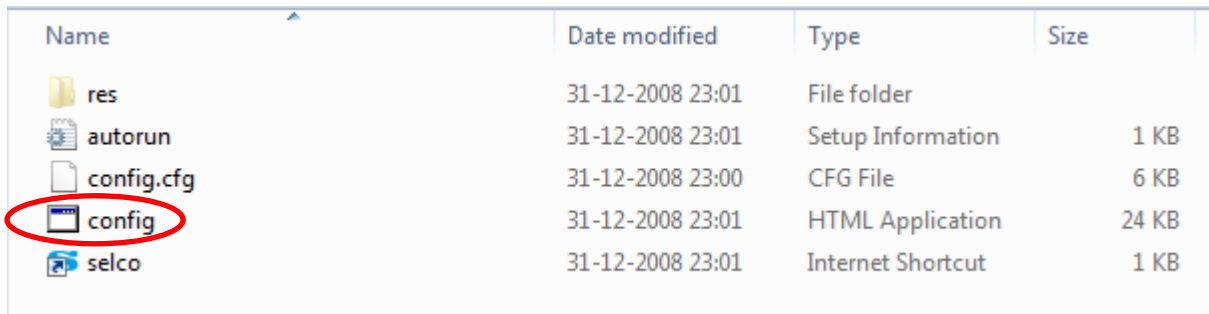

Name	Date modified	Type	Size
res	31-12-2008 23:01	File folder	
autorun	31-12-2008 23:01	Setup Information	1 KB
config.cfg	31-12-2008 23:00	CFG File	6 KB
config	31-12-2008 23:01	HTML Application	24 KB
selco	31-12-2008 23:01	Internet Shortcut	1 KB

## 11.3 General description of buttons in the configuration tool

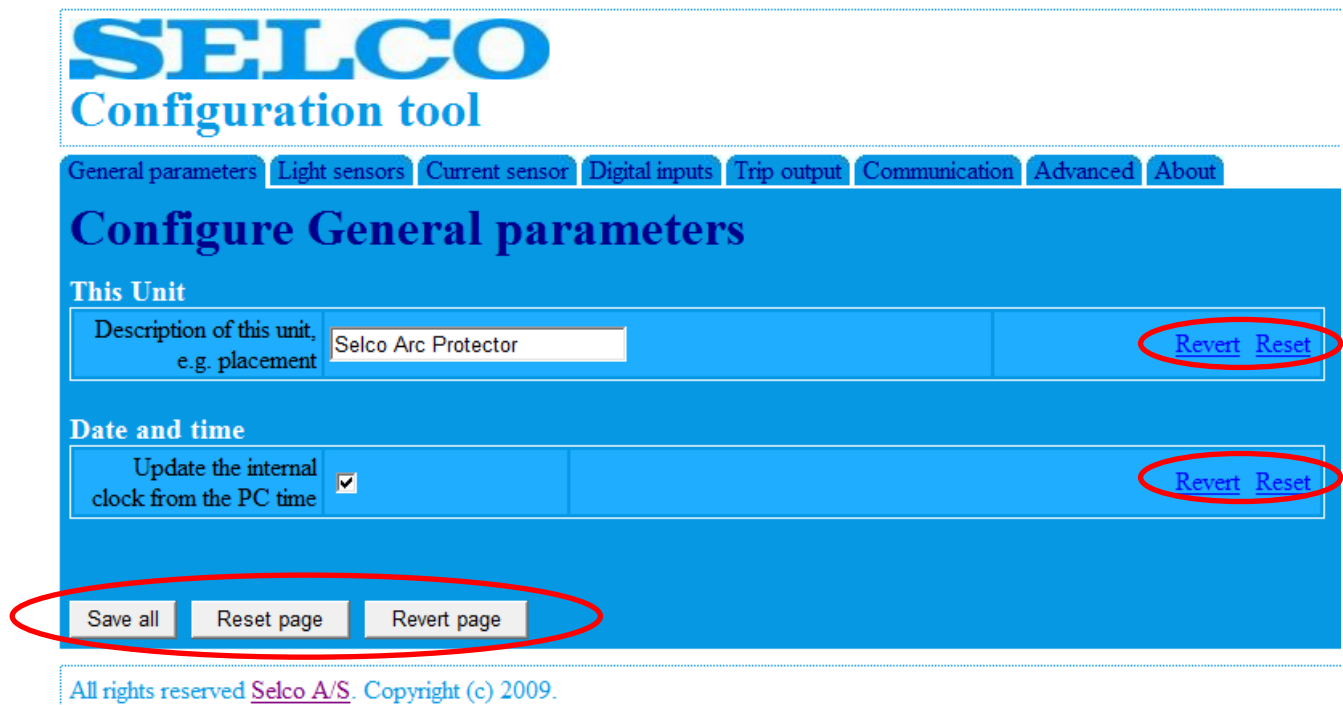

**SELCO**  
Configuration tool

General parameters | Light sensors | Current sensor | Digital inputs | Trip output | Communication | Advanced | About

### Configure General parameters

**This Unit**

Description of this unit, e.g. placement: Selco Arc Protector Revert Reset

**Date and time**

Update the internal clock from the PC time  Revert Reset

Save all Reset page Revert page

All rights reserved Selco A/S. Copyright (c) 2009.

### 11.3.1 Revert

Revert will re-establish the original configuration of the selected parameter to the state when the configuration was last saved.

### 11.3.2 Reset

Reset will restore the factory default configuration for the selected parameter

### 11.3.3 Save all

Save all will save the current adjustments in the config.hta file. Please note that the settings will first be activated on the D1000 module when the USB cable is disconnected.

### 11.3.4 Reset page

Reset page will restore the factory default configuration for all parameters on the selected screen.

### 11.3.5 Revert page

Revert page will re-establish the original configuration for all parameters on the selected screen to the state when the configuration was last saved.

## 11.4 General Parameters:

# SELCO

## Configuration tool

General parameters | Light sensors | Current sensor | Digital inputs | Trip output | Communication | Advanced | About

### Configure General parameters

#### This Unit

Description of this unit, e.g. placement	<input type="text" value="Selco Arc Protector"/>	<a href="#">Revert</a> <a href="#">Reset</a>
---	--	--

#### Date and time

Update the internal clock from the PC time	<input checked="" type="checkbox"/>	<a href="#">Revert</a> <a href="#">Reset</a>
---	-------------------------------------	--

All rights reserved [Selco A/S](#). Copyright (c) 2009.

### This Unit

The first parameter is the name of the unit. (Usually this would be the switchboard name and number of the switchboard section the unit is mounted in)

### Date and time

Update the internal clock from the PC date and time.

## 11.5 Configuration of light sensors

[General parameters](#)
[Light sensors](#)
[Current sensor](#)
[Digital inputs](#)
[Trip output](#)
[Communication](#)
[Advanced](#)
[About](#)

### Configure Light sensors

**Common delays and limits**

Minimum arc time before trip	<input type="text" value="2"/> 100 us units	<a href="#">Revert</a> <a href="#">Reset</a>
Indicator blinks green when above	<input type="text" value="75% of trip level"/>	<a href="#">Revert</a> <a href="#">Reset</a>

**Sensor 1**

Sensor description, e.g. placement	<input type="text" value="Sensor 1"/>	<a href="#">Revert</a> <a href="#">Reset</a>
Sensor type	<input type="text" value="None"/>	<a href="#">Revert</a> <a href="#">Reset</a>

**Front panel sensor**

Use front sensor as trip sensor	<input type="checkbox"/>	<a href="#">Revert</a> <a href="#">Reset</a>
Trip level	<input type="text" value="100"/> Percent of Trip Level adjust	<a href="#">Revert</a> <a href="#">Reset</a>

### 11.5.1 Common delays and limits

This parameter configures the trip, alarm levels and delay time for the arc detection.

Minimum arc time before trip	Adjustment of delay time for the arc detection in $\mu\text{s} \times 100$ (microseconds x 100) Above example means a delay time of $2 \mu\text{s} \times 100 = 200 \mu\text{s}$
Indicator flashes green when above	This is the pre alarm level for the arc detection. Adjustment in % of light intensity at trip level (trip level is adjusted on the front dial of D1000). Above example means light intensity $>75\%$ of trip level will give alarm (sensor indicator LED green flashing).

### 11.5.2 Sensor 1

The example shows the configuration of sensor input 1. All other sensor inputs are shown below Sensor 1 and can be configured in the same way.

Sensor description, e.g. placement	Name of the sensor. (Usually the name of the switchboard section the sensor is placed in)
Sensor type	Configuration of sensor type. Following types can be configured: A1000 point sensor A0200 point sensor A2000 fiber sensor A1100 personal point sensor None (input disabled)

Sensors with cable monitoring (A1000 and A2000) are automatically recognized by D1000 once they are connected. Therefore A1000 and A2000 do not need to be configured.

If sensors without cable monitoring are used (A0100/ A0200) they must be chosen otherwise D1000 generates sensor fault for the respective input.

Both A0100 and A0200 uses A0200 settings.

### 11.5.3 Front panel sensor

This is the configuration of the build in sensor of the D1000.

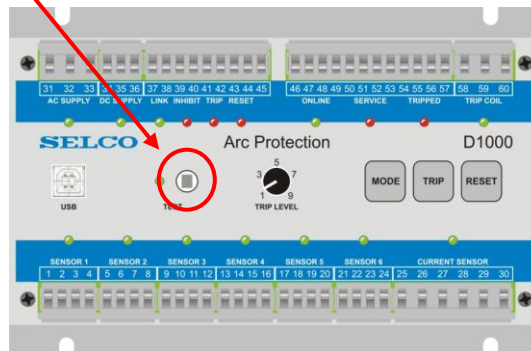

Use front sensor as trip

If this check box is marked, the front panel sensor will be used for monitoring (tripping the breaker). If not marked, it will be used for adjustment of sensitivity only.

Trip Level

Adjustment of the arc trip level for the front sensor. Adjustment in % of light intensity at trip level (trip level is adjusted on the front dial of D1000). Above example means light intensity >100 % of trip level will give C/B trip from the front sensor.

## 11.6 Configuration of current sensor

General parameters | Light sensors | **Current sensor** | Digital inputs | Trip output | Communication | Advanced | About

### Configure Current sensor

**Setup**

Enable inhibit if current is below a limit?	<input type="checkbox"/>	<a href="#">Revert</a> <a href="#">Reset</a>
Enable trips on overloads?	<input type="checkbox"/>	<a href="#">Revert</a> <a href="#">Reset</a>
Enable trips on shorts?	<input type="checkbox"/>	<a href="#">Revert</a> <a href="#">Reset</a>
Full scale current	<input type="text" value="5000"/> milliampere (CT secondary)	<a href="#">Revert</a> <a href="#">Reset</a>

**Limits and time delays**

Indicator blinks when above	<input type="text" value="100"/> Percent of full scale current	<a href="#">Revert</a> <a href="#">Reset</a>
Inhibit function allows trip above	<input type="text" value="100"/> Percent of full scale current	<a href="#">Revert</a> <a href="#">Reset</a>
Overload protection trip at peaks above	<input type="text" value="120"/> Percent of full scale current	<a href="#">Revert</a> <a href="#">Reset</a>
Time delay for overload protection trip	<input type="text" value="10"/> 100 us units	<a href="#">Revert</a> <a href="#">Reset</a>
Short protection trip at peaks above	<input type="text" value="400"/> Percent of full scale current	<a href="#">Revert</a> <a href="#">Reset</a>
Time delay for short protection trip	<input type="text" value="10"/> 100 us units	<a href="#">Revert</a> <a href="#">Reset</a>

Save all | Reset page | Revert page

### 11.6.1 Setup

Configuration of trip condition for the D1000:

- Trip on arc detection alone
- Trip only on arc detection AND over current detection (current inhibit)

#### Enable inhibit if current is below a limit?

Set a tick mark in this check box if the arc detection is to be enabled by an over current detection (C/B trip only with arc & over current detection)

**Setup**

Enable inhibit if current is below a limit?	<input checked="" type="checkbox"/>
---	-------------------------------------

No tick mark in the check box if the arc detection is to trip the C/B upon arc detection alone.

**Setup**

Enable inhibit if current is below a limit?	<input type="checkbox"/>
---	--------------------------

**Enable trips on overloads?**

The overload protection can work independently from the arc detection. When enabled, the D1000 can trip the C/B on overload alone, without presence of an arc fault like a normal over current relay.

Set a tick mark in this check box if the over current protection is to be enabled.

No tick mark in the check box if the over current protection is to be disabled.

Enable trips on overloads?	<input checked="" type="checkbox"/>
Enable trips on overloads?	<input type="checkbox"/>

**Enable trips on short circuits?**

The short circuit protection works independently from the arc detection. This means the D1000 can trip the C/B on short circuit alone, without presence of an arc, like a normal over current relay.

If the short circuit protection is to be enabled, set a tick mark in this check box.

If the short circuit protection is to be disabled, there should be no tick mark in the check box.

Enable trips on shorts?	<input checked="" type="checkbox"/>
-------------------------	-------------------------------------

Enable trips on shorts?	<input type="checkbox"/>
-------------------------	--------------------------

**Scaling of Current transformer**

This is the adjustment of the rated current of the secondary side of the current transformer.

Following adjustment means a 5A CT is fully used (secondary current =5A at rated current on primary side).

Full scale current	<input type="text" value="5000"/>	milliampere (CT secondary)
--------------------	-----------------------------------	----------------------------

## 11.6.2 Limits and time delays

### Pre-alarm

The over current pre-alarm function is adjusted in % of full scale current (see 11.6.1 Scaling of current transformer).

When the pre-alarm is triggered, the current sensor LED will start flashing green.

Indicator blinks when  
above  Percent of full scale current

### Trip inhibit

If the D1000 is configured to trip only in case it detects an arc fault AND over current, the over current level can be adjusted here.

Inhibit function allows  
trip above  Percent of full scale current

The trip level is expressed in % of full scale current.

If the current level is exceeded the current sensor LED will light red (steady light). The circuit breaker will not be tripped yet, as tripping condition is over current and arc detection.

### Over current protection trip level

The over current protection trip level is expressed in % of full scale current. If this function is enabled and the over current level is exceeded for the duration of the time delay, D1000 will trip the circuit breaker.

If the current level is exceeded, the current sensor LED will start flashing green. After expiration of the trip delay, D1000 will trip the C/B and the current sensor LED will start flashing red.

Overload protection trip  
at peaks above  Percent of full scale current

### Time delay for over current protection trip

The time delay for over current trip is expressed in a factor x 100  $\mu$ s.

Following adjustment means a trip delay of 2000000  $\mu$ s -> 2 s

Time delay for overload  
protection trip  100 us units

The range is from 100  $\mu$ s to 2 s.

### Short circuit protection trip level

The short circuit protection trip level is expressed in % of full scale current. If this function is enabled and the short circuit level is exceeded for the duration of the time delay, D1000 will trip the circuit breaker.

If the current level is exceeded, the current sensor LED will start flashing green. After expiration of the trip delay, D1000 will trip the C/B and the current sensor LED will start flashing red.

Short protection trip at  
peaks above  Percent of full scale current

### Time delay for over short circuit protection trip

The time delay for short circuit trip is expressed in a factor x 100  $\mu$ s.

Following adjustment means a trip delay of 2000000  $\mu$ s -> 2 s

Time delay for overload  
protection trip  100 us units

The range is from 100  $\mu$ s to 2 s.

Time delay for short  
protection trip  100 us units

# 11.7 Configuration of digital inputs

General parameters | Light sensors | Current sensor | **Digital inputs** | Trip output | Communication | Advanced | About

## Configure Digital inputs

**Inhibit input**  
 Inhibit input: Inhibit when pulled low [Revert](#) [Reset](#)

**Trip input**  
 Trip input: Trip when pulled low [Revert](#) [Reset](#)

**Reset input**  
 Reset input: Reset when pulled low [Revert](#) [Reset](#)

Save all | Reset page | Revert page

### 11.7.1 Inhibit input

#### Normally open, no cable monitoring

Following adjustment gives trip inhibit when the input is connected to COM (terminal 45):

**Inhibit input**  
 Inhibit input: Inhibit when pulled low

This is the factory default configuration.

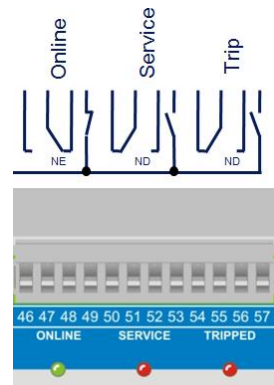

#### Normally open, with cable monitoring

Following adjustment gives trip inhibit when the input is connected to COM (terminal 45). Circuit check is active:

**Inhibit input**  
 Inhibit input: Inhibit when low with circuit check

#### Normally closed, without cable monitoring

Following adjustment gives trip inhibit when the input open. There is no circuit check for this input when configured to normally open:

**Inhibit input**  
 Inhibit input: Inhibit when not pulled low

### Inhibit input disabled

When configured as follows the inhibit input is disabled (no function on inhibit input):



Inhibit input Disabled

## 11.7.2 Trip input

### Normally open, no cable monitoring

Following adjustment gives external trip when the input is connected to COM (terminal 45):

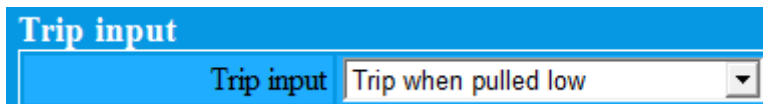

Trip input Trip when pulled low

This is the factory default configuration.

### Normally open, with cable monitoring

Following adjustment gives external trip when the input is connected to COM (terminal 45). Circuit check is active:

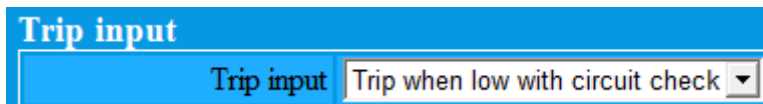

Trip input Trip when low with circuit check

### Normally closed, without cable monitoring

Following adjustment gives external trip when the input open. There is no circuit check for this input when configured to normally open:

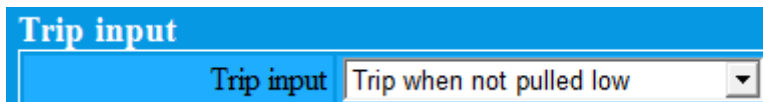

Trip input Trip when not pulled low

### Inhibit input disabled

When configured as follows the external trip input is disabled (no function on external trip input):

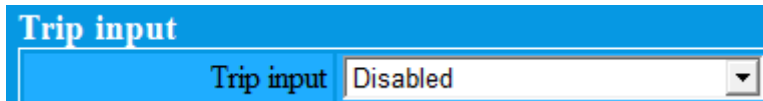

Trip input Disabled

### 11.7.3 Reset input

#### Normally open, no cable monitoring

Following adjustment gives reset when the input is connected to COM (terminal 45):

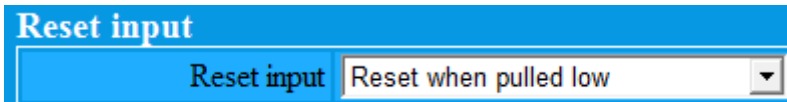

The screenshot shows a blue header bar with the text "Reset input". Below it is a white box with a blue border containing the text "Reset input" and a dropdown menu. The dropdown menu is currently set to "Reset when pulled low".

This is the factory default configuration.

#### Normally open, with cable monitoring

Following adjustment gives reset when the input is connected to COM (terminal 45). Circuit check is active:

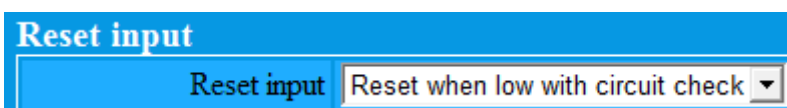

The screenshot shows a blue header bar with the text "Reset input". Below it is a white box with a blue border containing the text "Reset input" and a dropdown menu. The dropdown menu is currently set to "Reset when low with circuit check".

#### Normally closed, without cable monitoring

Following adjustment gives reset when the input open. There is no circuit check for this input when configured to normally open:

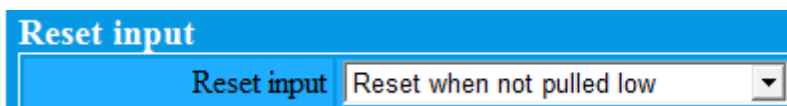

The screenshot shows a blue header bar with the text "Reset input". Below it is a white box with a blue border containing the text "Reset input" and a dropdown menu. The dropdown menu is currently set to "Reset when not pulled low".

#### Inhibit input disabled

When configured as follows the reset input is disabled (no function on reset input):

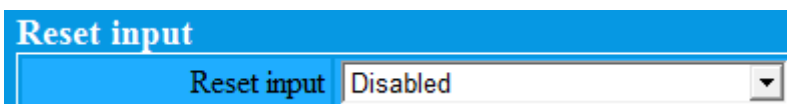

The screenshot shows a blue header bar with the text "Reset input". Below it is a white box with a blue border containing the text "Reset input" and a dropdown menu. The dropdown menu is currently set to "Disabled".

## 11.8 Configuration of trip output

[General parameters](#)
[Light sensors](#)
[Current sensor](#)
[Digital inputs](#)
[Trip output](#)
[Communication](#)
[Advanced](#)
[About](#)

### Configure Trip output

**IGBT output**

Trip switch type	Undervoltage coil (Active when off) ▾	<a href="#">Revert</a> <a href="#">Reset</a>
Hold time before autorelease	<input type="text" value="2"/> seconds	<a href="#">Revert</a> <a href="#">Reset</a>
Online falls if IGBT switch is unpowered	<input checked="" type="checkbox"/>	<a href="#">Revert</a> <a href="#">Reset</a>

### Under voltage coil

Following configuration enables the under voltage trip coil:

Trip switch type

This is the default configuration.

### Shunt trip

Following configuration enables the shunt trip coil:

Trip switch type

### Pulse length of trip signal

The pulse length of the trip signal can be configured.

When tripping the under voltage coil or shunt coil, D1000 will activate and hold the trip coil output during the configured hold time.

Following adjustment means a trip signal of 2 s:

Hold time before autorelease  seconds

The trip signal can be adjusted between 1 s and 10 s. Default is 2 s.

**Alarm in case trip voltage is missing**

The trip output is working with an external trip voltage in order to match the different types of under voltage coils and shunt trips. In case this external voltage is lost an alarm can be triggered. The D1000 will then de-activate the ONLINE output. This is only relevant when using a shunt trip coil, as the D1000 cannot trip the circuit breaker without trip voltage.

In default configuration this alarm is enabled:

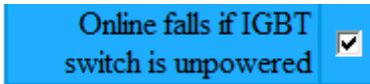

For disabling this alarm remove the tick mark:

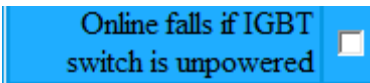

## 11.9 Advanced settings

General parameters | Light sensors | Current sensor | Digital inputs | Trip output | Communication | **Advanced** | About

### Advanced

**Configuration**

Reset configuration to factory defaults(!)	<input type="checkbox"/>	<a href="#">Revert</a> <a href="#">Reset</a>
--	--------------------------	--

**Internal drives**

Reset configuration drive to factory default	<input type="checkbox"/>	<a href="#">Revert</a> <a href="#">Reset</a>
Reset log drive to factory default	<input type="checkbox"/>	<a href="#">Revert</a> <a href="#">Reset</a>

Save all | Reset page | Revert page

For setting the configuration to factory default, place a tick mark in the respective check box. After next power up of the D1000 the unit will revert to factory default configuration.

## 11.10 About

General parameters | Light sensors | Current sensor | Digital inputs | Trip output | Communication | Advanced | **About**

### About

**Version info**

*Configuration saved at 2009-01-01T00:53:30*  
*Product type: D1000.SERIES 0*  
*Product SW Version: 2010-03-09 01.00.07*  
*Product HW Version: to be done*  
*HW serial number: 0*

Save all | Reset page | Revert page

This screen gives information on the hardware and firmware revision of the D1000

## 12 Event logging

The built-in USB connection provides easy access to a real-time event log, which provides detailed diagnostic information about all events, including near misses and events related to daily operation (e.g. configuration changes, test, reset, and power cycling).

For reading the log, connect the D1000 to the PC using the USB interface.

The D1000 log drive will appear in the file manager:

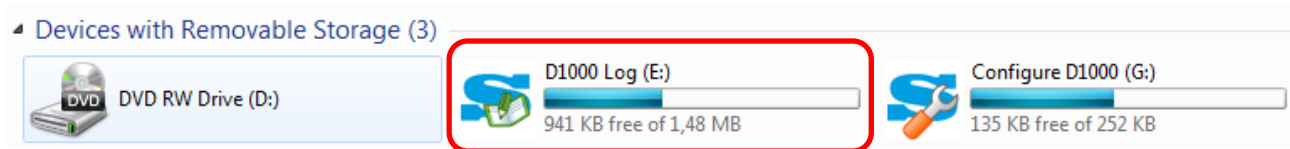

For sharing of log files, simply copy the log.txt file. For viewing the log double click on the log\_view file:

Name	Date modified	Type	Size
events	31-12-2008 23:01	File folder	
res	31-12-2008 23:01	File folder	
autorun	31-12-2008 23:01	Setup Information	1 KB
log	31-12-2008 23:53	Text Document	26 KB
log_view	31-12-2008 23:01	HTML Application	4 KB
selco	31-12-2008 23:01	Internet Shortcut	1 KB

### Example for Log View:

```

2011-01-06T10:27:30 The trip happened due to Sensor 1, Sensor 2, Sensor 3, Sensor 4, and happened on 2011-01-06T10:27:21 .
2011-01-06T10:27:30 The output was tripped more than once, latest on 2011-01-06T10:27:21
2011-01-06T10:27:30 The trip was not inhibited.
2011-01-06T10:27:30 The output was released on 2011-01-06T10:27:23
2011-01-06T10:27:30 Trip log for event 56 saved
2011-01-06T10:27:31 Logging and resetting event 56
2011-01-06T10:27:31 Event log for trip 56:
2011-01-06T10:27:31 The trip happened due to Sensor 1, Sensor 2, Sensor 3, Sensor 4, and happened on 2011-01-06T10:27:21 .
2011-01-06T10:27:31 The output was tripped more than once, latest on 2011-01-06T10:27:21
2011-01-06T10:27:31 The trip was not inhibited.
2011-01-06T10:27:31 The output was released on 2011-01-06T10:27:23
2011-01-06T10:28:04 Error: Sensor 4 failed circuit check - protection of Sensor 4 sector lost!
2011-01-06T10:28:16 Sensor 4 found in circuit check.
2011-01-06T10:28:16 Error cleared: Sensor 4 found - protection of Sensor 4 sector operational
2011-01-06T10:28:26 USB cable inserted



```

## 13 Commissioning

The D1000 will work out of the box, and will always trip if a sensor input exceeds the limit shown on the front, no matter if the circuit check is proclaiming the cable to be broken. However, we recommend doing a few simple tests on the sensors to ensure that problems on the sensors or cabling will be detected and reported.

D1000 will detect sensors at boot and report if they disappear, but in most installations, it is advantageous to store the sensor configuration permanently. This is easily done by configuring the installed sensors either via USB as shown above, or via the method shown here.

### 13.1 Configuration of installed sensors



1. Press  to switch to SERVICE mode (SERVICE LED will ignite with a steady red light)
2. Press and hold  for a few seconds to start the test sequence
3. All sensors and indicators will flash for 10 seconds while the system tests all sensors. This clears the sensor configuration<sup>1</sup>.
4. Move a light source towards the TEST sensor until the LED turns off.
5. Observe that all connected sensors have now started flashing<sup>2</sup>. Move the light source towards each sensor until it turn off. This should happen at approximately the same distance that was used before the Test sensor reacted. The indicator LEDs associated with the sensor will change to steady green at the same time.
6. Return to the central unit and confirm that all indicators at connected sensors are showing a steady green light. Now illuminate the TEST sensor again to store the results.
7. The system will now flash green on all sensors briefly, store the results in non-volatile memory, and go back to normal SERVICE mode.
8. Press  to switch back to ONLINE mode. The sensors are now configured permanently, and the system will give an alarm if a sensor malfunctions.

---

<sup>1</sup> If something is not as expected during the test, it can be cancelled by pressing Reset at any time. To go back to the previous configuration requires a power cycle of the unit.





<sup>2</sup> Sensors that do not include circuit check cannot be detected automatically. However, illuminating them will include them in the sensor list and make them light up – but they still cannot be tested while the system is running.

## 13.2 Testing the sensors



1. Press  to switch to SERVICE mode (SERVICE LED will ignite with steady red light)
2. Confirm that all indicators at connected sensors are showing a steady green light
3. Confirm that all connected sensors are giving a double flash of red light periodically, indicating that the sensor is being tested
4. Point a light source at a sensor and check that both the sensor LED and the indicator LED changes to steady flashing, and that the Tripped indicator turns on.
5. Repeat step 4 for the remaining sensors
6. Confirm that all indicators at connected sensors are now showing a flashing red light
7. Press  to switch back to ONLINE mode (ONLINE LED will ignite with steady green light)

The Test can be cancelled at any time by pressing , which will go back to online mode.

## 13.3 Testing the trip coil

1. Make sure that the system is ready for test (TRIP COIL output will be tripped during this procedure)
2. Press  to switch to SERVICE mode (SERVICE LED will ignite with steady red light)
3. Press  and hold it pressed for a few seconds to activate the TRIP COIL output
4. Observe that the connected trip coil trips correctly. The output will reset itself after the configured time, typically 2 seconds
5. Reset the TRIP by pressing 
6. Press  to switch back to ONLINE mode (ONLINE LED will ignite with steady green light)

### 13.4 Full operation Test (online)

1. Make sure that the system is ready for test (TRIP COIL output will be tripped during this procedure)
2. Press  to switch to ONLINE mode (ONLINE LED will ignite with steady green light)
3. Confirm that there is a steady green light in the sensor LED of each connected sensor (shows that sensors are connected and healthy)
4. Confirm that a short red flashing light occurs periodically in each detector (indicates that the sensor circuit is being checked)
5. Move a light source towards the TEST sensor and confirm that it starts flashing
6. Move the light source towards a sensor. The indicator LED will at some point start flashing with a green light, indicating that the light intensity is approaching the trip limit.
7. Now move light source closer to the sensor. Confirm that the TRIP COIL output trips and that the LEDs of the TRIP COILs sensor and detector changes to a flashing red light (trip)
8. Reset the TRIP by pressing  to re-enable the system
9. Repeat steps 6 to 8 for the remaining sensors

### 13.5 Adjustment of Sensor Sensitivity

1. Adjust  the trip level setting – lower numbers for higher sensitivity and greater distances

## 14 Specifications

### D1000 Arc Protection Unit D1000.0010

Voltage Supply	85 to 230 V AC 8 to 60 V DC, 100 to 250 V DC Can charge a 24 V backup/trip battery – Lead acid gel cell
Trip coil output:	IGBT switch, 200 $\mu$ s on-time, 2 s pulsed (configurable)
Trip coil voltage range:	24 to 600 V DC / 24 to 440 V AC
Signal contacts:	Online, Service, Tripped
Sensitivity:	10.000 to 25.000 lux (trip level adjustment 1 to 9)
Current inputs:	3-phase 5A (75 A / 1 s)
Burden:	< 0,25 VA / inputs at 5 A
Current range:	1.5 to 3.0 x $I_n$ (7.5 to 15 A)
Response time:	Less than 1 ms (arc fault), less than 1 ms (over current)
Number of detectors:	Up to 6
Interface:	USB
Power consumption:	< 3 W
Ambient temperature_	-25 to + 70 °C
Dimensions (W x H x D):	200 x 130 x 52 mm
Mounting:	35 mm DIN Rail or screw-in
Altitude:	Below 2.000 meter / 6.500 ft: Normal operation Above 2.000 meter / 6.500 ft: Use 24V DC supply and shunt trip coils only, as the lower air pressure decreases cooling efficiency. Above 4.000 meter / 13.000 ft: Maximum ambient operating temperature is lowered to 50°C. Above 5.000 meter / 16.000 ft: Contact SELCO for guidance and operating procedures.

	<b>A1000 Sensor A1000.0010</b>	<b>A2000 Sensor A2000.0010</b>
<b>Type:</b>	Point sensor	Fibre optical sensor
<b>Detection Area:</b>	180 x 360 ° - 2 m	360 °
<b>Length:</b>	10 m shielded cable	8 m flexible fiber
<b>Circuit Check</b>	Built-in LED for visual feedback	Built-in LED for visual feedback
<b>Dimensions</b>	32 x 52 x 21 mm	32 x 55 x 19 mm

**Approvals/standards**

EMC standards: EN60255-26

Enclosure: IP 20